

User's Manual

EDGE

www.proelgroup.com

PROEL
SOUND REINFORCEMENT



EDGE Series Users Manual

Version 1.0

5 september 2005

Contents

1	Introduction	3
1.1	Components	3
1.2	Design techniques	4
2	The EDGE series	7
3	Technical specifications	9
3.1	EDGE212P	10
3.2	EDGE218SP	16
3.3	EDGE121SP	20
3.4	EDGE15CXPB	24
3.5	EDGE12CXP	31
3.6	EDGE8CXP	38
3.7	EDGE25P	44
3.8	EDGE112SP	50
3.9	DSO26	54
4	Guide to dimensioning the system	57
4.1	Sound Reinforcement	57
4.2	The phenomenon of the comb filtering	57
4.3	Importance of the DSO26 processor	62
4.4	Subwoofer delay time adjustment	63
4.5	Notes on the amplifier power requirements	64
4.6	Power lost by the cables	65
5	Guide to flying the EDGE system	67
5.1	The flying system	67
5.2	Material used for flying the system	68
5.3	Load limits	73
5.4	Safety information	75
5.5	Inspection and maintenance	76

Contents

5.6	Responsibility	77
5.7	Set up operation	77
5.8	Operations which should be carried out	85
5.9	Operations which should be avoided	85
6	EDGE Accessories	87
7	Typical applications	91
7.1	Basic concert system	92
7.2	Basic concert system with a floor mounted sub	94
7.3	Medium size concert system	96
7.4	Large concert system	98

1 Introduction

The EDGE series is comprised of loudspeakers with mid to high directivity designed to satisfy the requirements of the professional audio market. The choice of high quality material and very high performance components, coupled with avant-garde design techniques allows EDGE to be distinguished for its superior audio quality, high efficiency and outstanding level of reliability.

The EDGE systems have been developed to satisfy the most demanding sound reinforcement applications from live concerts to corporate events.

The adoption of robust yet simple mechanical solutions allows the quick and practical set up of flown arrays for live applications while at the same time providing flexible yet secure solutions for fixed installations.

Thanks to the application of new concepts and ideas not usually found in traditional array systems, EDGE allows the user to reach higher levels of performance. The system is highly versatile and simple to use. The flexibility of EDGE allows rational and functional installations to be realised with the guarantee of an elevated sound quality.

1.1 Components

Edge series' transducers feature some of the finest technical solutions available on the market. Both power handling and sound quality have been accurately optimised. Carbon fibre reinforced cones and waterproof treatments assure long-term reliability and safe operation in any environment.

All of the transducers used feature an exceptionally high motor strength and, in the case of the 21" woofer, a double layer magnet assembly has been used to deliver an outstanding 34 Tm BL product. The Double Silicon Spider centring device assures a high restoring force, controlling the cone motion and greatly increasing the peak power handling. The dual-layer voice coil is wound inside and outside of the coil former thus doubling the metal-to-metal heat radiation surface.

These features result in a significant reduced power compression. De-modulating ring devices are largely employed in almost every transducer for

1. Introduction

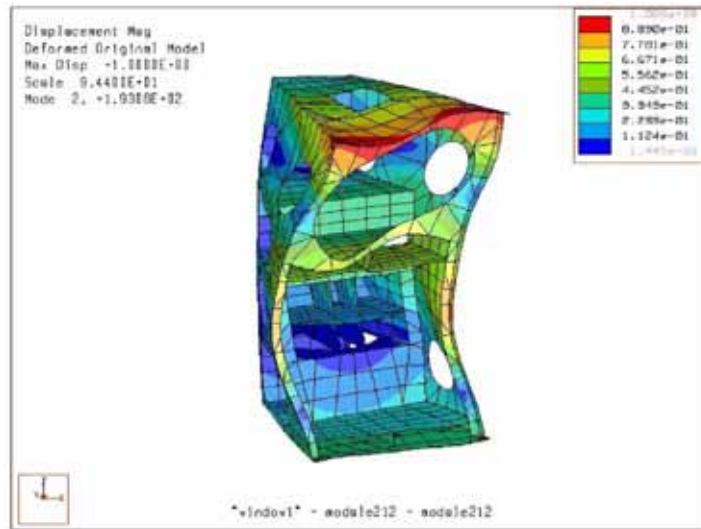

Figure 1.1: Finite Element Modelling (FEM) analysis

maximized mid-range distortion reduction and over-excursion control.

1.2 Design techniques

The EDGE series loudspeakers are designed for maximum performance and effectiveness. Advanced design techniques, such as FEM (Finite Element Modelling) were employed with special proprietary optimisation techniques. These techniques go towards giving the EDGE series a superior sound quality. The EDGE systems, thanks to sophisticated directivity analysis have been designed with particular attention to the control of the sound irradiated.

The wave guides have been accurately simulated and then modelled using advanced software instruments. Sophisticated directivity analysis instruments have been used during the optimisation process together with latest generation measurement systems. This has allowed the calculation of the necessary transference functions for the DSP which can optimise the operation of the whole system.

The design of the system allows easy coupling of EDGE systems, even in large arrays, reducing to a minimum the interference and thereby guaranteeing a uniform and constant coverage.

The FEM analysis has been utilised to see the behaviour of the cabinet internally, analysing possible stationary frequencies and resonance. Finite elements are also used to analyse the possible resonance of every metal part used

and the structural resistance of the system when suspended, guaranteeing a high safety level.

FEM analysis

The research carried out for the optimisation of the cabinets of the EDGE systems has produced a study which was presented at the 116th AES convention held in Berlin in 2004 entitled *Analysis and minimization of unwanted Resonances in Loudspeaker Systems via FEM techniques*. Thanks to the act of minimalising the resonance of the cabinets, the EDGE systems provide an audio quality without precedence even at very high sound pressure levels.

2 The EDGE series

The EDGE series is composed of various high quality models of several different typologies designed to satisfy a vast range of sound reinforcement requirements.



The principle module is the concert system EDGE212P, a traditional array system with a co-axial driver loaded on an asymmetrical horn and two horn loaded 12" mid range woofers. The EDGE212P has been realised with modern components and avant-garde technology. The EDGE212P can be coupled with either the floor mounted 21" direct radiating subwoofer EDGE121SP or with the EDGE218SP double 18" direct radiating bass unit. The EDGE212P and

2. The EDGE series

EDGE218SP can both be flown using the Fly Track hardware. This system allows array composition in a fast and versatile way. The EDGE concert systems are extremely flexible in their use allowing reinforcement of small clubs and huge arenas with a constant high quality and exceptionally equilibrated sound.

For monitoring needs the EDGE series features the EDGE15CXPB which has a 1.5" driver coaxially mounted in a 15" woofer and the EDGE12CXP which has a 1.5" driver coaxially mounted in a 12" woofer. The ultra compact EDGE8CXP 1" driver coaxially mounted in an 8" woofer has been developed to be used for both monitoring and for installations where it can be coupled with the small EDGE112SP 12" direct radiating subwoofer. The smallest model in the range is the EDGE25P. This features two 5,25" woofers and a dome tweeter which has been horn loaded in a symmetric WTW configuration. The EDGE25P has been designed to operate as a theatre front-fill, for small installations, conferences and pubs where a powerful but low profile system is needed. Being 16 ohm, it is possible to link several of these units together in parallel.

The processing of the EDGE speaker systems had been entrusted to the DSO26 digital processor. The DSO26 contains in its internal memory all of the programmes required for the optimisation of the EDGE series.

3 Technical specifications

The technical data featured in the following specifications have been measured in the PROEL laboratories anechoic chamber. All measurements have been done in free space using state of the art measurement methods. On the base of these measurements, the models of the entire EDGE series have been released for the EASE electro-acoustic simulation software. The updated models are available on the internet site sound.proelgroup.com and can be downloaded free of charge.

EDGE212P

Features

- Highly efficient traditional array system
- Coaxial driver on a asymmetric wave-guide
- Flying Track suspension system
- DDR Double Demodulating Ring, DSS Double Silicon Spider, ISV Interleaved Sandwich Voice Coil

Description

The EDGE212P is a 3 way, horn loaded system of high efficiency. The mid-bass section is equipped with two 12" loudspeakers connected in parallel and coupled on the same horn wave guide. Each cone has an impedance of 16 ohm and has a demodulation ring for reduced distortion. An elliptic-spheroid wave guide housing a special 2" compression driver reproduces the mid-high frequency band from 800 Hz upwards. This driver is internally divided into two sub-systems: a 4" annular membrane reproduces from 800 Hz to 7 kHz and the very high frequencies from 7 kHz upwards are reproduced, through a passive filter, by a 2" plastic film membrane which is mounted co-axially to the former. The wave guide used has been designed specifically to allow an excellent directivity control which is kept constant from 600 Hz upwards. This feature allows the EDGE212P to be coupled in a coherent way even in very large arrays, distributing the audio energy in a uniform way over the listening area.

The wave guides of the EDGE212P are inclined downwards by 5°. In the flying configuration, such a down-tilt makes it possible to create more rational arrays. In situations where it is not possible to fly the system, the down-tilt aids



in the coverage of the listening area. The result is an improved and predictable coverage, a good audio balance across the whole array once installed, well distributed energy and an homogenous frequency response reducing many of the problems traditionally associated with large arrays of loudspeakers. This all works to improve the fidelity and intelligibility obtainable even in conditions of high reverberation.

Technical characteristics

System	
System Type	3-way horn loaded full-range bi-amp
Frequency Response	125 Hz - 20 kHz (-3dB,+6dB)
Coverage Angle H. (-6 dB)	50° average, 315 Hz to 20 kHz (5° downtilt)
Coverage Angle V. (-6 dB)	40° average, 315 Hz to 20 kHz
Directivity Index (DI)	12.8 average, 315 Hz to 20 kHz
Maximum Peak Output	139 dB @ 1m
Signal Processing	Proel DSO26
Transducers	
Mid Frequency Device	2 x 12" woofer - 3" voice coil - horn loaded
Nominal Impedance	8 Ω
Power Rating	800 W AES, 1600 W program
Sensitivity	107 dB SPL (2.83 V @ 1m)
High Frequency Device	2" coaxial compression driver - horn loaded
Nominal Impedance	16 Ω
Power Rating	150 W AES, 300 W program
Sensitivity	112 dB SPL (4 V @ 1m)
Mechanical Data	
Construction	trapezoidal (25°) 18 mm birch plywood, internally reinforced with paint finish
Flying System	flying track
Dimensions (WxHxD)	58.5 x 98.8 x 68.5 cm
Weight	86.5 kg

Architects' and Engineers' Specifications

The system shall be passive, two way, with a frequency response of 125 Hz to 20 kHz and a constant coverage angle of 50°H x 40°V. The system shall have a co-axial driver built onto a horn wave-guide with a constant directivity of 50°H x 40°V and an impedance of 16 ohm, a coaxial diaphragm of 4" with a 2" throat and a power handling of 150 W AES. The system shall also have two mid-low loudspeakers each of 12" in size, built on a loaded bass-reflex horn

3. Technical specifications

wave-guide. Each of these loudspeakers shall be 16 ohm with a 3" voice coil. The speaker shall have a flying system which allows the realisation of columns of speakers hung by way of connection points on the back of the speaker, allowing the regulation of the angles between the speakers by means of a connection cable system positioned at the front. The speakers shall be constructed from 18 mm Birch Plywood. It shall have a trapezoid wedge angle of 25°. It shall be 98.5 cm high, 58.5 cm wide at the front, 29 cm wide at the back with a depth of 68.5 cm. The system shall be the PROEL EDGE212P.

Dimensions

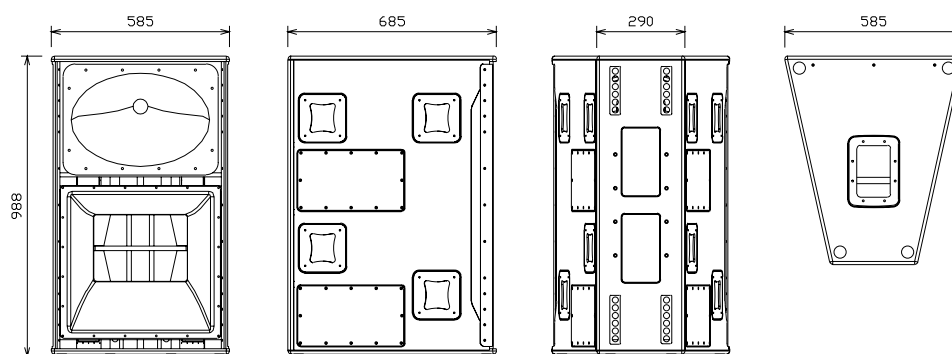

Connections

2 Neutrik Speakon NL4MP connectors in parallel.

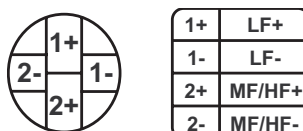

Graphics

Frequency response:

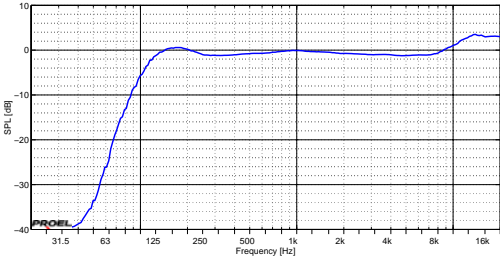

Directivity index:

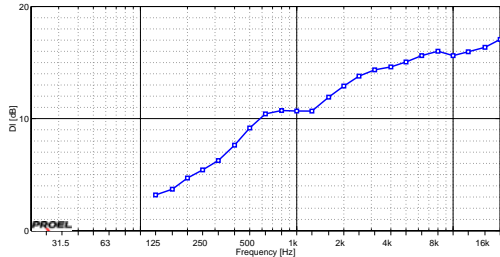

Beamwidth diagram (-6 dB):

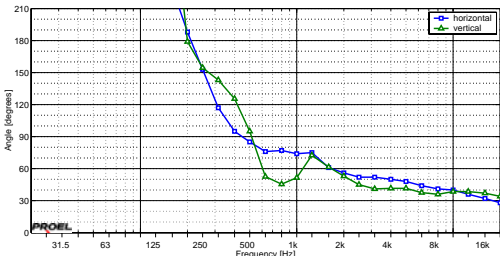

3. Technical specifications

Attenuation map (horizontal):

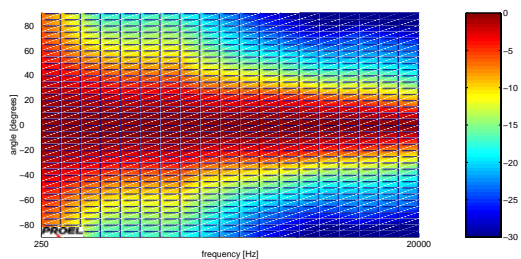

Polar diagram (horizontal):

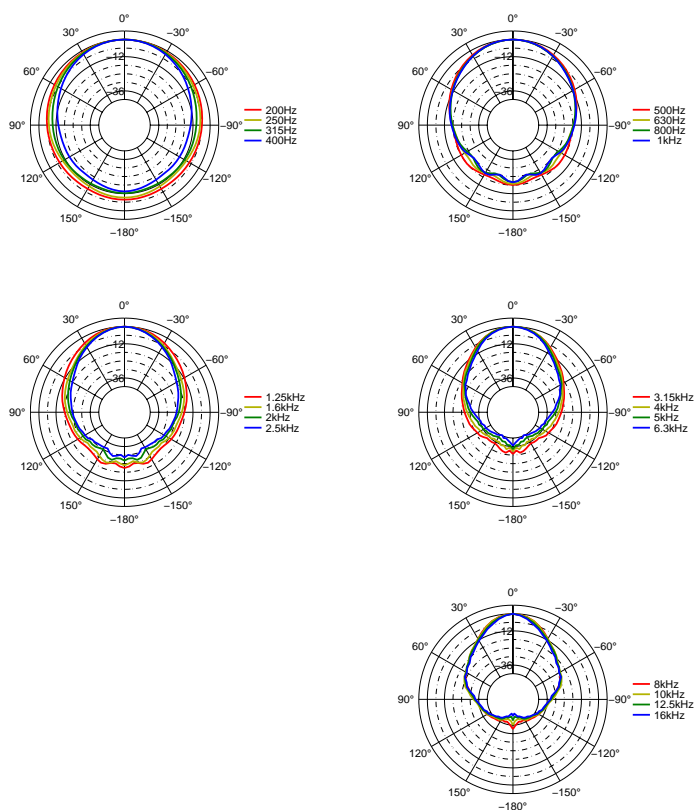

Attenuation map (vertical):

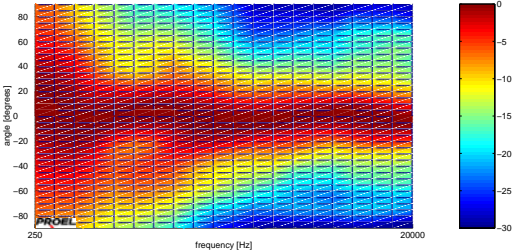

Polar diagram (vertical):

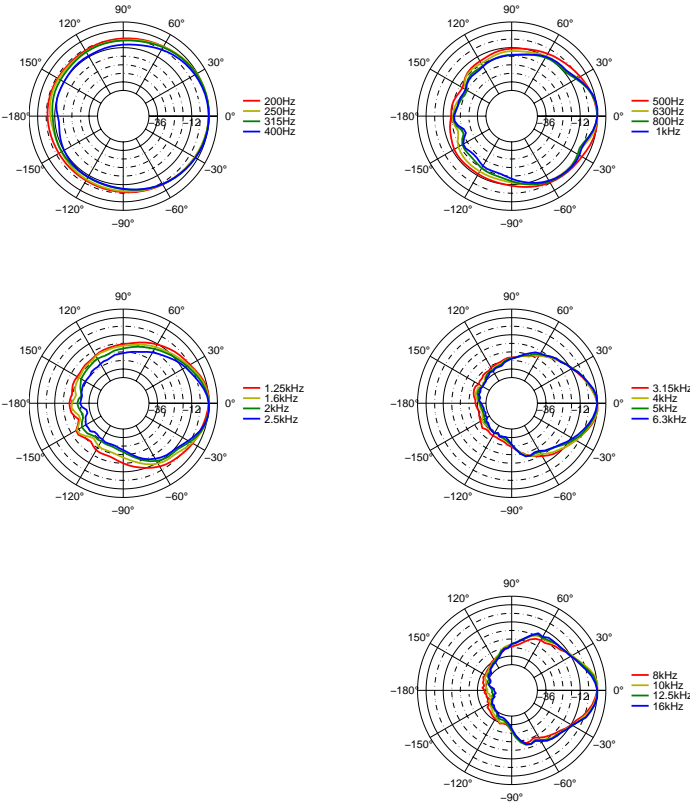

EDGE218SP

Features

- Array suspendable Bass Unit
- Suspension system: Fly-Track
- Highly damped box
- DDR Double Demodulating Ring, DSS Double Silicon Spider, ISV Interleaved Sandwich Voice Coil

Description

The suspendable Bass unit EDGE218SP represents the necessary complement to the EDGE212P in situations where it is absolutely necessary to have a suspended system for the reproduction of the bass frequencies. The EDGE218SP is a direct radiating unit equipped with two 18" speakers and is capable of reproducing high impact bass, working between 45 to 130 Hz. The box has been designed to be highly damped which allows the system to have a larger active radiation surface in the available space. This permits the mutual coupling effect between several units. As such, when in an array this extends the bass response even lower and avoids the confused audio effects associated with large bass arrays. The shape of the box, the suspension system and the weight allow the EDGE218SP to be easily coupled with the EDGE212P without any mechanical difficulties.



Technical characteristics

System	
System Type	direct radiation bass-reflex
Frequency Response	40 Hz - 100 Hz (-3 dB)
Maximum Peak Output	132 dB @ 1m
Signal Processing	Proel DSO26
Transducers	
Low Frequency Device	2 x 18" woofer - 4" voice coil
Nominal Impedance	8 Ω
Power Rating	800 W AES, 1600 W program
Sensitivity	97 dB SPL (2 V @ 1m, 4 Ω both speakers linked)
Mechanical Data	
Construction	trapezoidal (25°) 18/24 mm birch plywood, internally reinforced with paint finish
Flying System	flying track
Dimensions (WxHxD)	58.5 x 98.8 x 68.5 cm
Weight	81 kg

Architects' and Engineers' Specifications

The system shall be a passive subwoofer with a frequency response of 40 Hz to 100 Hz. The system shall have two direct radiating 18" loudspeakers loaded in a bass reflex configuration. Each of these loudspeakers shall be 8 ohms with a 4" voice coil. The speaker shall have a flying system which allows the realisation of columns of speakers hung by way of connection points on the back of the speaker and allows the regulation of the angles between the speakers by means of a connection cable system positioned at the front. The speakers shall be constructed from 18 mm Birch Plywood. It shall have a trapezoid wedge angle of 25°. It shall be 98.5 cm high, 58.5 cm wide at the front, 29 cm wide at the back with a depth of 68.5 cm. The system shall be the PROEL EDGE218SP.

3. Technical specifications

Dimensions

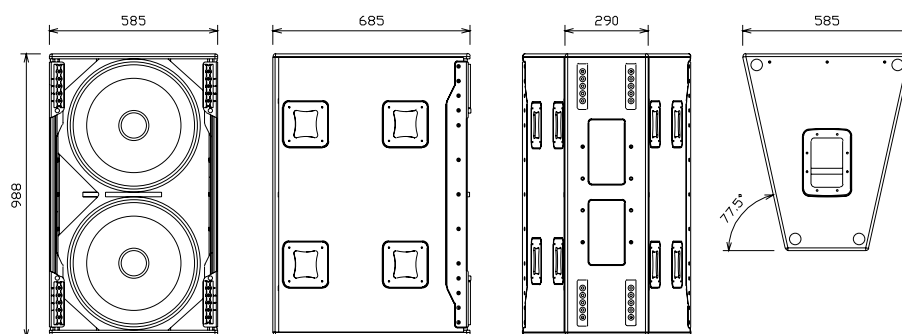

Connections

2 Neutrik Speakon NL4MP connectors in parallel.

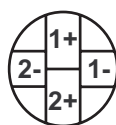

1+	LF1+
1-	LF1-
2+	LF2+
2-	LF2-

Graphics

Frequency response:

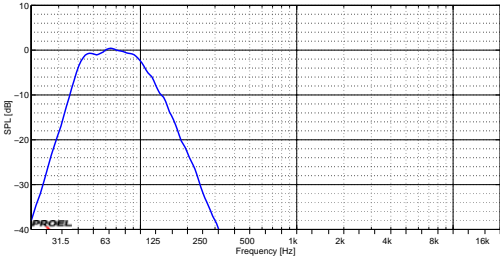

Impedance¹:

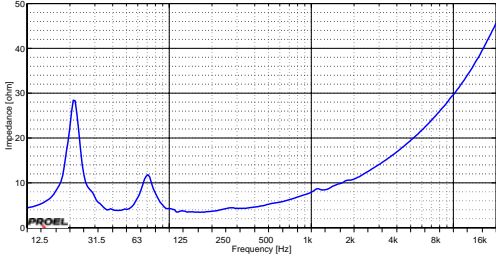

¹The two woofers are connected in parallel.

EDGE121SP

Features

- Direct radiating Bass unit
- 21" woofer with 4" four layer ISV voice coil
- DDR Double Demodulating Ring, DSS Double Silicon Spider

Description

The 21" direct radiating subwoofer EDGE121SP is a system which completes the bass frequency response of the EDGE212P. Working between 30 and 80 Hz, with incredible excursion control and excellent power handling. Capable of working at 800W (AES) continuous power, it can handle peaks of up to 6dB higher (3200W) without any damage. Thanks to the robust mechanical cone suspension system DSS (Double silicone spider), to the double demodulating rings (DDR) and to the over damped box in which it sits, the EDGE121SP is capable of producing high quantities of energy in the bass frequencies with high definition and control.



Technical characteristics

System	
System Type	direct radiation bass-reflex
Frequency Response	32 Hz - 80 Hz (-3 dB)
Maximum Peak Output	130 dB @ 1m
Signal Processing	Proel DSO26, Proel ASO25
Crossover Frequency	from 80 Hz to 160 Hz
Input Power Rating	800 W AES, 1600 W program
Sensitivity	98 dB SPL (2.83 V @ 1m)
Nominal Impedance	8 Ω
Transducer	
Low Frequency Device	21" woofer - 4" four layer voice coil
Mechanical Data	
Construction	18/24 mm birch plywood, internally reinforced with paint finish
Mounting Pole	1 x top
Dimensions (WxHxD)	58.4 x 76.5 x 81.0 cm
Weight	63.5 kg

Architects' and Engineers' Specifications

The system shall be a passive subwoofer with a frequency response from 32 Hz to 80 Hz. The system shall be a direct radiating 21" woofer in a bass reflex configuration. The loudspeaker shall be 8 ohm with a 4" voice coil. The speaker box will be constructed from 18/24 mm Birch plywood with internal reinforcement. The box shall have a rectangular shape, 77.5 cm high, 58 cm wide and 68.5 cm deep. The system shall be called the PROEL EDGE121SP.

3. Technical specifications

Dimensions

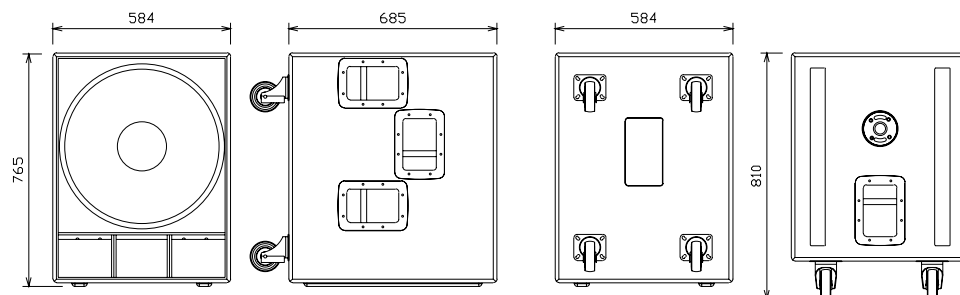

Connections

2 Neutrik Speakon NL4MP connectors in parallel.

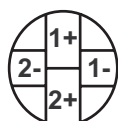

1+	IN+
1-	IN-
2+	
2-	

Graphics

Frequency response:

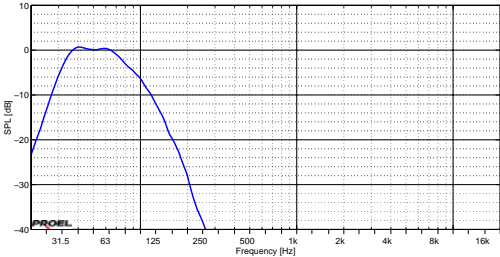

Impedance:

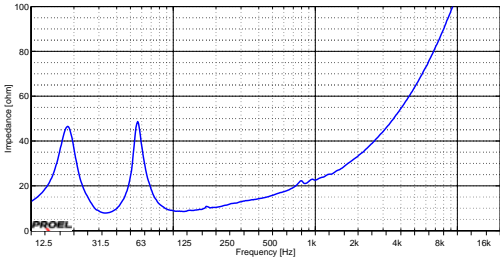

EDGE15CXPB

Features

- Coaxial monitor with a 15" woofer
- Low profile, ideal for television applications
- Full range or Bi-amp modes

Description

The monitor EDGE15CXPB is a highly efficient 2 way low profile system. The bass frequencies are reproduced by a high excursion 15" woofer with a 4" voice coil. The woofer is equipped with a copper ring on the pole piece to achieve the lowest distortion in the critical vocal range. A small spherical wave guide, housed coaxially in the magnet assembly, loads a 1.5" neodymium-magnet, titanium-diaphragm compression driver that delivers a 65° symmetric coverage for 1.4kHz upwards.



The EDGE15CXPB monitor system is equipped with a high-performance, high-quality, passive filter. The EDGE15CXPB can be internally switched to Bi-Amp operation and driven by the DSO26 digital processor using the appropriate memory program.

The extremely high performance coaxial transducer results in even tonal balance and high intelligibility even at extremely high power levels. Moreover, its shallow and compact shape gives it a discrete presence on stage, particularly for T.V. broadcast performances.

EDGE15CXPB can be also be utilised as a reinforcement system for the front-fill or down fill as well as being stand mounted with for example, the EDGE121SP, to created a drum-fill.

Technical characteristics

System	
System Type	coaxial 2-way vented enclosure
Frequency Response	60 Hz - 20 kHz (± 6 dB)
Coverage Angle H. (-6 dB)	65° average, 630 Hz to 20 kHz
Coverage Angle V. (-6 dB)	65° average, 630 Hz to 20 kHz
Directivity Index (DI)	12.4 average, 630 Hz to 20 kHz
Maximum Peak Output	131 dB @ 1m
Signal Processing	Proel DSO26 (biamp)
Input Power Rating	900 W AES, 1800 W program
Sensitivity	99 dB SPL (2.83V @ 1m)
Nominal Impedance	8 Ω
Transducers	
Low Frequency Device	15" woofer - 4" voice coil
Nominal Impedance	8 Ω
Power Rating	900 W AES, 1800 W program
Sensitivity	99 dB SPL (2,83 V @ 1m)
High Frequency Device	1.5" compression driver - coaxial
Nominal Impedance	8 Ω
Power Rating	75 W AES, 150 W program
Sensitivity	109 dB SPL (2,83 V @ 1m)
Mechanical Data	
Construction	monitor (42°) 18 mm birch plywood, internally reinforced with paint finish
Flying Points	4 x M10 lateral
Mounting Pole	1 x lateral
Dimensions (WxHxD)	58.4 x 39.4 x 61.9 cm
Weight	33 kg

Architects' and Engineers' Specifications

The system shall be a passive two way monitor with a frequency response of 60 Hz to 20 kHz and a constant coverage angle of 65°H x 65°V. The system shall have an 15", 8 ohm, driver with a 1,5" diaphragm and a power handling of 75 W AES positioned co-axially to the woofer. The system shall also have an 8 ohm bass speaker with a 4" voice coil and a power handling of 900 W AES loaded in a bass reflex configuration. The speaker shall be provided laterally with 4 x M10 attachment points and with a top-hat for mounting on a speaker stand. The speaker shall be constructed from 18 mm Birch plywood reinforced internally in an asymmetric trapezoid shape with a monitor angle of 42°. The

3. Technical specifications

height shall be 39.4 cm, width 58.5 cm and depth of 61.9 cm. The system shall be the PROEL EDGE15CXPB.

Dimensions

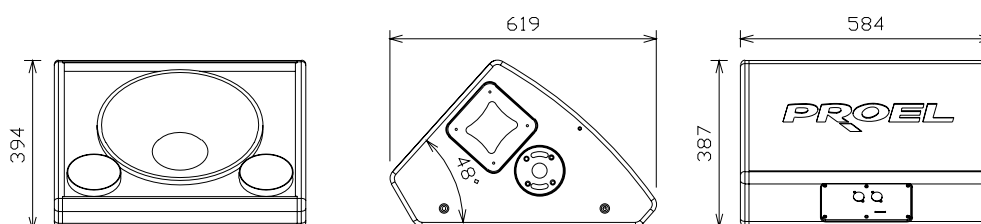

Connections

The EDGE15CXPB can work in two modes: Full range or Bi-amp. In the bi-amplified mode, the internal crossover filter is disconnected and it is therefore necessary to use the DSO26 processor as crossover filter and protection of the components. In Full range mode, the internal crossover is connected. The EDGE15CXPB gives the best performance in the Bi-amp mode with the DSO26 processor.

FULL RANGE:

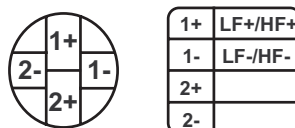

BI-AMP:

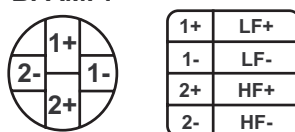

The two Neutrik Speakon NL4MP are ever connected in parallel. When the FULL RANGE mode is selected, the Speakon connectors take the signal from the 1+ and 1- pins and send this signal to the internal passive crossover. When the BI-AMP mode is selected, the connectors take the LF signal from the 1+ and 1- pins and the HF from the 2+ and 2- pins. In this case, the passive crossover is by-passed and therefore it is necessary to use the PROEL DSO26 digital processor to filter the signal sent to the transducers for correct operation and not be damaged.

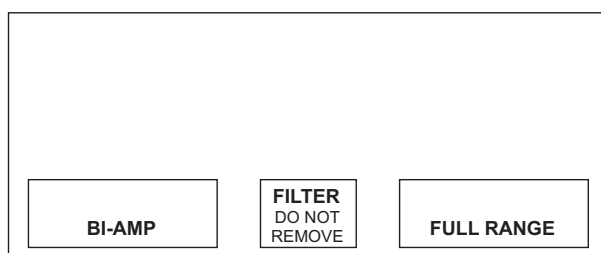

To select the operational mode of the monitor it is necessary to open the connection panel. Remove the internal connector from the FULL RANGE position to BI-AMP and vice-versa. Do not move, for any reason, the central "FILTER" connection.



It is possible to visualise when the amp is in BI-AMP mode, using the BI-AMP window positioned in the lower right corner of the connection panel.

3. Technical specifications

Graphics

Frequency response:

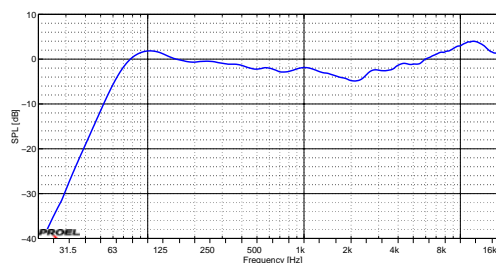

Directivity index:

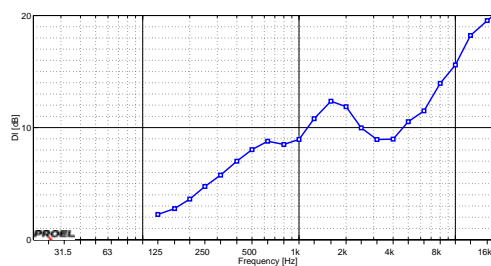

Beamwidth diagram (-6 dB):

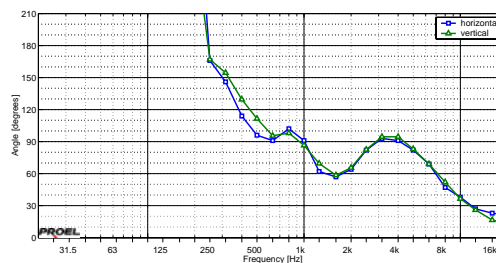

Attenuation map (horizontal):

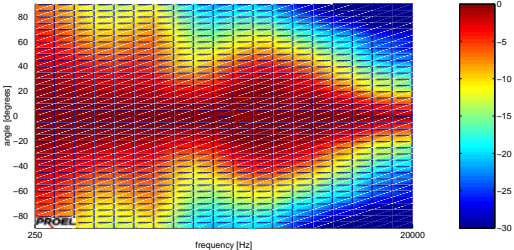

Polar diagram (horizontal):

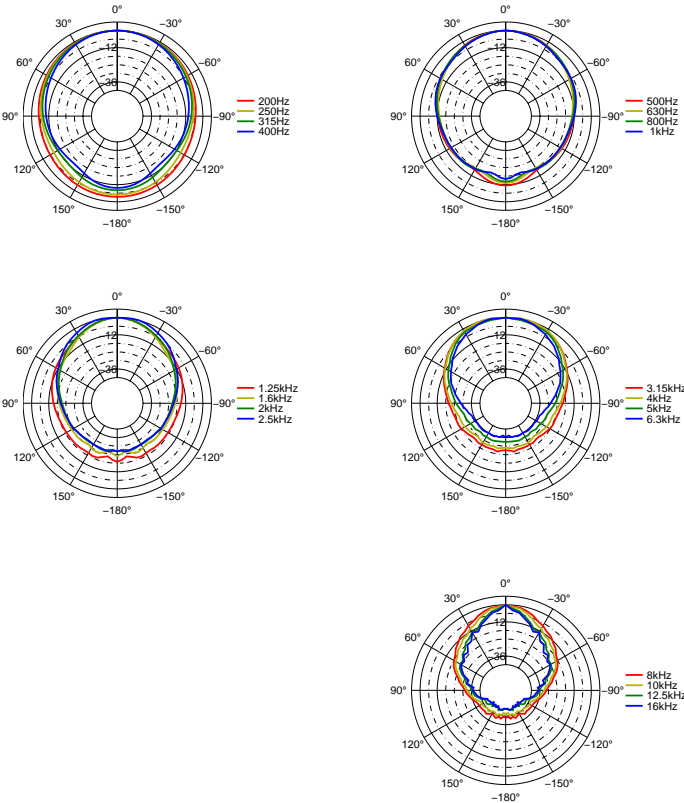

3. Technical specifications

Attenuation map (vertical):

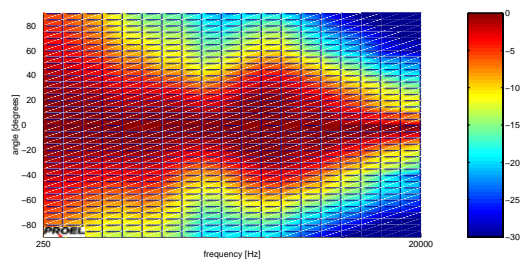

Polar diagram (vertical):

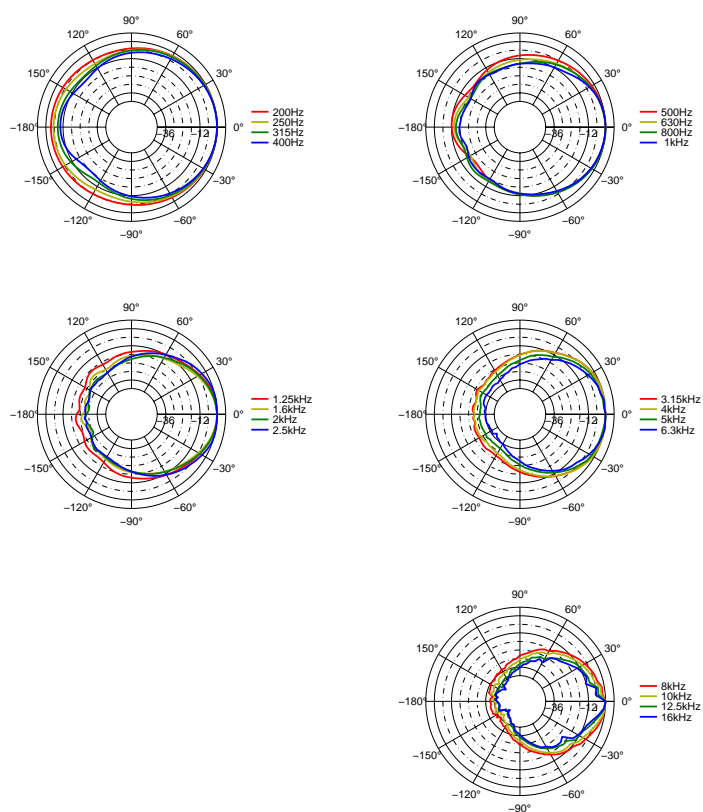

EDGE12CXP

Features

- Coaxial monitor with a 12" woofer
- Low profile, ideal for television applications
- Full range or Bi-amp modes

Description

The monitor EDGE12CXP is a highly efficient 2 way low profile system. The bass frequencies are reproduced by a high excursion 12" woofer with a 3" voice coil. The woofer is equipped with a copper ring on the pole piece to achieve the lowest distortion in the critical vocal range. A small spherical wave guide, housed coaxially in the magnet assembly, loads a 1.5" neodymium-magnet, titanium-diaphragm compression driver that delivers a 65° symmetric coverage for 1.4kHz upwards. The EDGE12CXP monitor system is equipped with a high-performance, high-quality, passive filter. The EDGE12CXP can be internally switched to Bi-Amp operation and driven by the DSO26 digital processor using the appropriate memory program.

The extremely high performance coaxial transducer results in even tonal balance and high intelligibility even at extremely high power levels. Moreover, its shallow and compact shape gives it a discrete presence on stage, particularly for T.V. broadcast performances.

EDGE12CXP can be also be utilised as a reinforcement system for the front-fill or down fill as well as being stand mounted with for example, the EDGE121SP, to created a drum-fill.



3. Technical specifications

Technical Characteristics

System	
System Type	coaxial 2-way vented enclosure
Frequency Response	75 Hz - 20 kHz (± 6 dB)
Coverage Angle H. (-6 dB)	65° average
Coverage Angle V. (-6 dB)	65° average
Directivity Index (DI)	12.4 average
Maximum Peak Output	127 dB @ 1m
Signal Processing	Proel DSO26 (biamp)
Input Power Rating	450 W AES, 900 W program
Sensitivity	98 dB SPL (2.83V @ 1m)
Nominal Impedance	8 Ω
Transducers	
Low Frequency Device	12" woofer - 3" voice coil
Nominal Impedance	8 Ω
Power Rating	450 W AES, 900 W program
Sensitivity	98 dB SPL (2.83 V @ 1m)
High Frequency Device	1.5" compression driver - coaxial
Nominal Impedance	8 Ω
Power Rating	75 W AES, 150 W program
Sensitivity	109 dB SPL (2.83 V @ 1m)
Mechanical data	
Construction	monitor (42°) 18 mm birch plywood paint finish
Flying Points	4 x M10 lateral
Mounting Pole	1 x lateral
Dimensions (WxHxD)	43.5 x 39.4 x 61.9 cm
Weight	25 kg

Architects' and Engineers' Specifications

The system shall be a passive two way monitor with a frequency response of 75 Hz to 20 kHz and a constant coverage angle of 65°H x 65°V. The system shall have an 8 ohm driver with a 1,5" diaphragm and a power handling of 75 W AES positioned co-axially to the woofer. The system shall have an 12", 8 ohm, bass speaker with a 3" voice coil and a power handling of 450 W AES loaded in a bass reflex configuration. The speaker shall be provided laterally with 4 x M10 attachment points and with a top-hat for mounting on a speaker stand. The speaker shall be constructed from 18 mm Birch plywood reinforced internally in an asymmetric trapezoid shape with a monitor angle of 42°. The

height shall be 39.4 cm, width 43.5 cm and depth of 61.9 cm. The system shall be the PROEL EDGE12CXP.

Dimensions

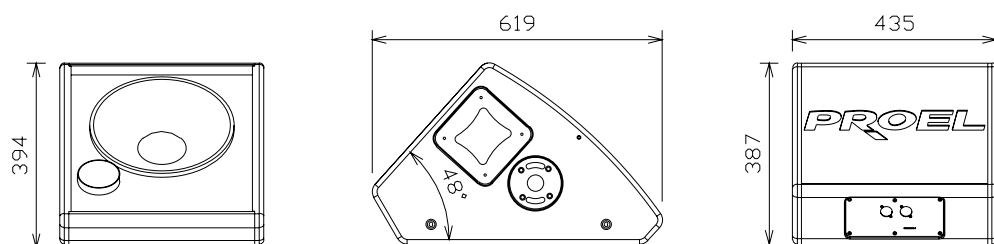

Connections

The EDGE12CXP can work in two modes: Full range or Bi-amp. In the bi-amplified mode, the internal crossover filter is disconnected and it is therefore necessary to use the DSO26 processor as crossover filter and protection of the components. In Full range mode, the internal crossover is connected. The EDGE12CXP gives the best performance in the Bi-amp mode with the DSO26 processor.

FULL RANGE:

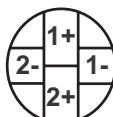

1+	LF+/HF+
1-	LF-/HF-
2+	
2-	

BI-AMP:

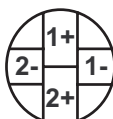

1+	LF+
1-	LF-
2+	HF+
2-	HF-

The two Neutrik Speakon NL4MP are ever connected in parallel. When the FULL RANGE mode is selected, the Speakon connectors take the signal from the 1+ and 1- pins and send this signal to the internal passive crossover. When the BI-AMP mode is selected, the connectors take the LF signal from the 1+ and 1- pins and the HF from the 2+ and 2- pins. In this case, the passive crossover is by-passed and therefore it is necessary to use the PROEL DSO26 digital processor to filter the signal sent to the transducers for correct operation and not be damaged.

3. Technical specifications

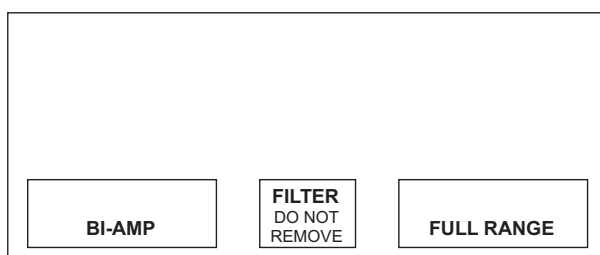

To select the operational mode of the monitor it is necessary to open the connection panel. Remove the internal connector from the FULL RANGE position to BI-AMP and vice-versa. Do not move, for any reason, the central FILTER connection.



It is possible to visualise when the amp is in BI-AMP mode, using the BI-AMP window positioned in the lower right corner of the connection panel.

Graphics

Frequency response:

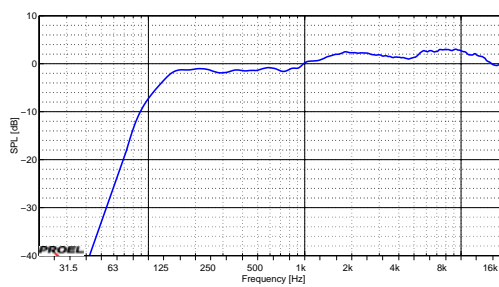

Directivity index:

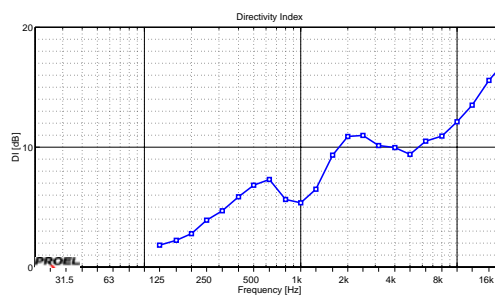

Beamwidth diagram (-6 dB):

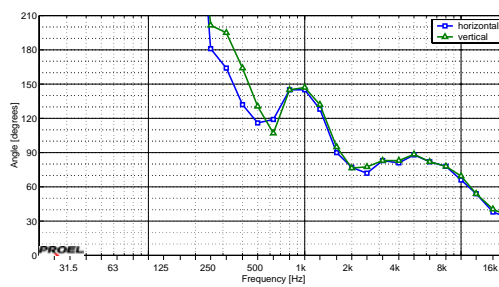

3. Technical specifications

Attenuation map (horizontal):

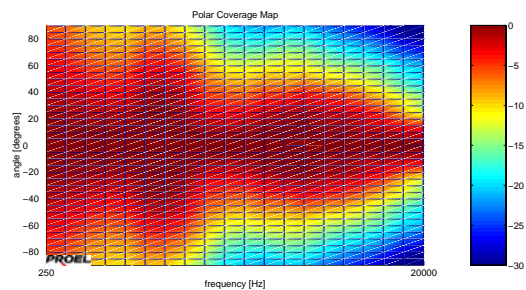

Polar diagram (horizontal):

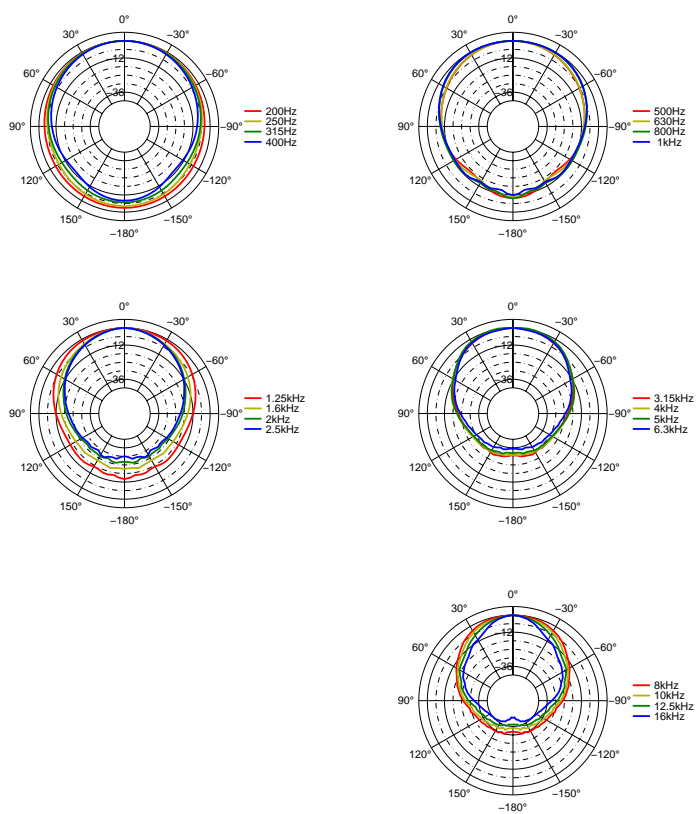

Attenuation map (vertical):

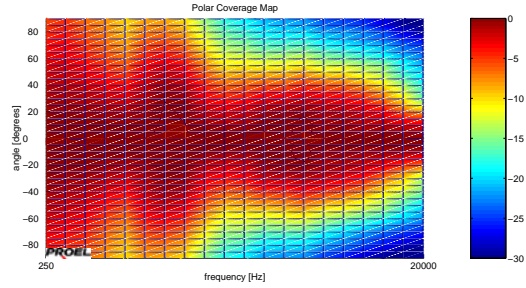

Polar diagram (vertical):

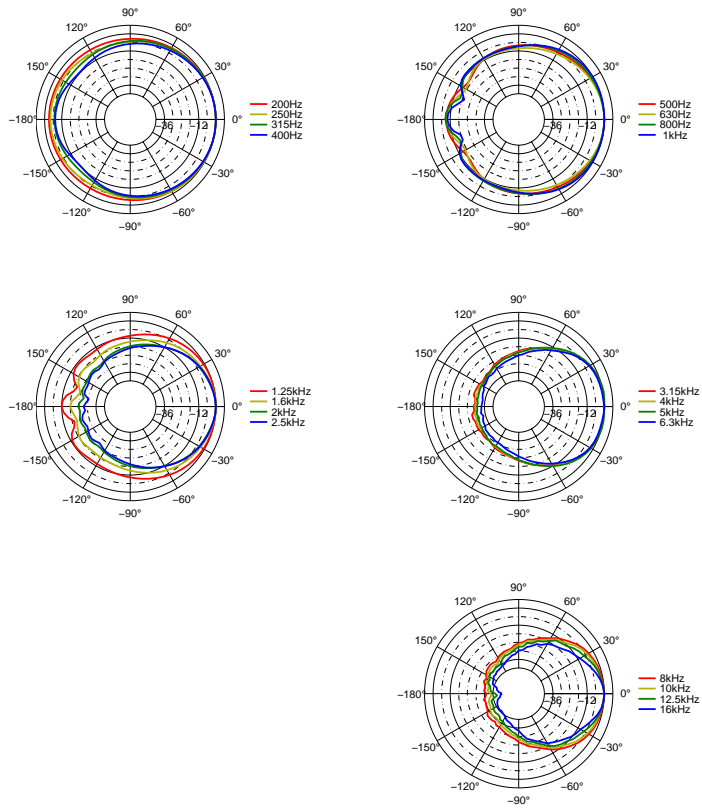

EDGE8CXP

Features

- Compact speaker system with a symmetric coverage of 85°
- Co-axial design

Description

The EDGE8CXP is a diffusion system with the characteristics of being truly compact and versatile. The custom made co-axial speaker has been developed on the specifics of the PROEL Research and Design laboratory. The results have been aimed at producing the best performance from an 8" woofer combined with a 1" driver. The woofer is comprised of an ISV (Interleaved Sandwich Voice Coil) and an aluminium casing. The double ventilated die-cast basket has been designed to have improved heat dissipation and thereby reduce the power compression level. The compression driver provides better excursion control and reduces

distortion through use of Ferro-fluid. The diaphragm has been constructed with a new synthetic material which, together with the reinforced radius design increases the rigidity and thereby avoiding the formation of uncontrolled vibrations. The phase plug is the result of a meticulous study and has been designed using 3D CAD software to realise a shape that guarantees a correct acoustic impedance which reduces dramatically the levels of distortion. The pressed Aluminium voice coil assures low distortion and high efficiency with good power handling. The EDGE8CXP has an internal 12dB per octave passive crossover with a PTC electronic protection. Version with 100 V constant voltage line transformer is also available, EDGE8CXTB black and EDGE8CXTW white.



Technical Characteristics

System	
System Type	coaxial 2-way vented enclosure
Frequency Response	80 Hz - 20 kHz (± 6 dB)
Coverage Angle H. (-6 dB)	85° averaged, 1 kHz to 20 kHz
Coverage Angle V. (-6 dB)	85° averaged, 1 kHz to 20 kHz
Directivity Index (DI)	9.7 averaged, 1 kHz to 20 kHz
Maximum Peak Output	121 dB @ 1m
Input Power Rating	225 W AES, 450 W program
Sensitivity	95 dB SPL (2.83 V @ 1m)
Nominal Impedance	8 Ω
Constant voltage transformer	optional 100 V EDGE8CXTB black, EDGE8CXTW white
Transducers	
Low Frequency Device	8" woofer - 2" voice coil
High Frequency Device	1" compression driver - coaxial
Mechanical Data	
Construction	monitor taper 45° 15 mm birch plywood with paint finish
Color	black EDGE8CXPB, white EDGE8CXPW
Flying Points	4 x M10 - top, bottom, rear
Mounting Pole	1 x bottom
Dimensions (WxHxD)	26 x 33 x 28 cm
Weight	10 kg

Architects' and Engineers' Specifications

The system shall passive two way with a frequency response of 80 Hz to 20 kHz and with a constant coverage angle of 85°H x 85°V. The system shall have an 8 ohm driver with a 1" diaphragm and a power handling of 75 W AES set co-axially to the woofer. The system shall have an 8", 8 ohm woofer with a 2" voice coil and a power handling of 225 W AES, loaded in a bass reflex configuration. The system shall be provided with 4 x M10 hanging points and shall feature a top-hat pole mounting system. The speaker box shall be constructed from 15 mm Birch plywood in an asymmetric trapezoid shape with a monitor angle of 45°. The height shall be 32 cm, width 26 cm and depth of 28 cm. The system shall be the PROEL EDGE8CXP.

3. Technical specifications

Dimensions

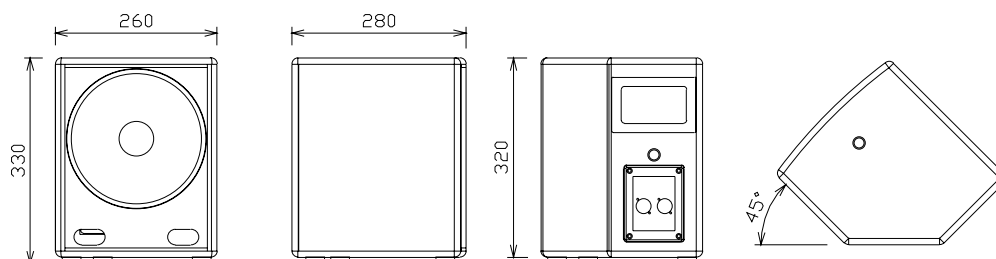

Connections

2 Neutrik Speakon NL4MP connectors in parallel.

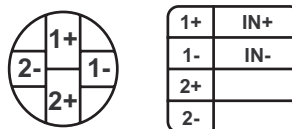

Graphics

Frequency response:

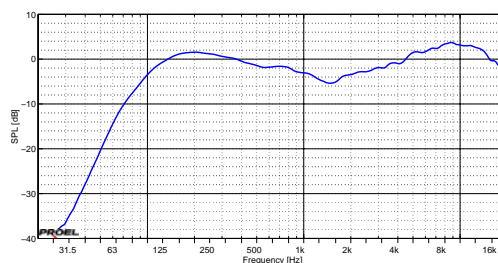

Directivity index:

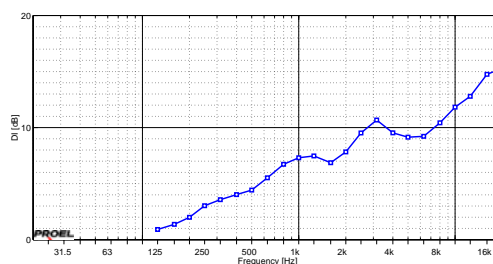

Beamwidth diagram (-6 dB):

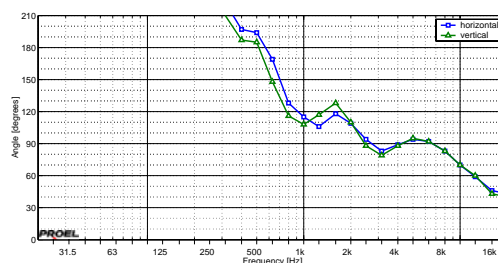

3. Technical specifications

Attenuation map (horizontal):

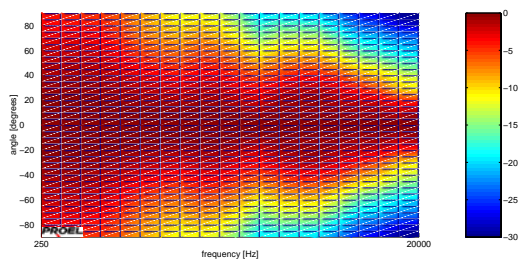

Polar diagram (horizontal):

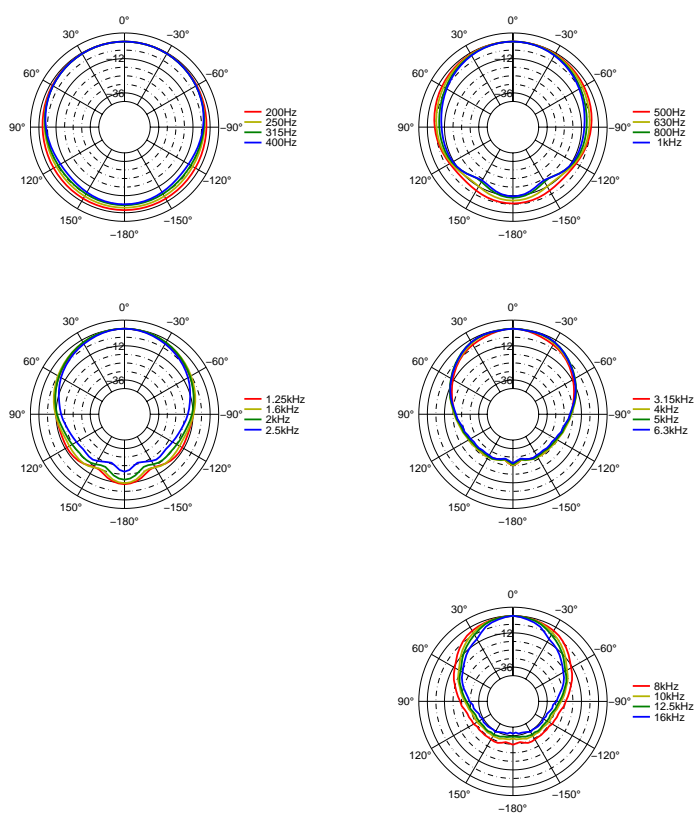

Attenuation map (vertical):

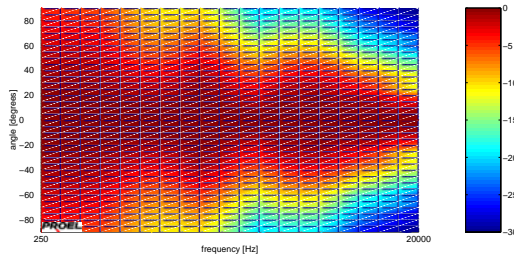

Polar diagram (vertical):

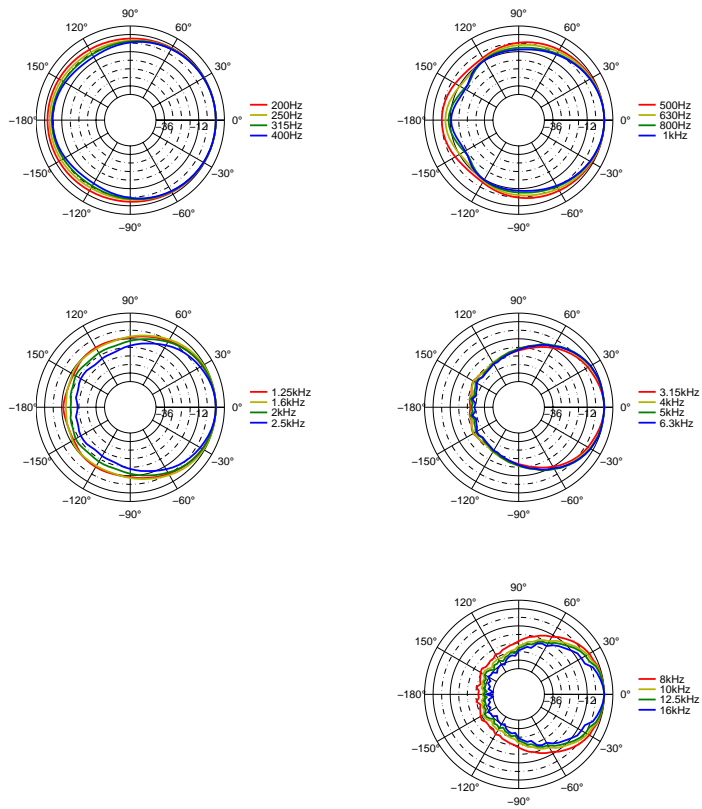

EDGE25P

Features

- WTW configuration with a spherical waveguide
- Easily configurable in small arrays

Description

The EDGE25P is a 2 way, full range passive system with an internal crossover and a PTC protection for the tweeter. Designed for near-field applications such as television, stage front, conferences theatres etc. The system is characterised by 2 x 5.25" woofers and a dome tweeter with a SWGH (Spherical Wave Guide Horn) in a WTW configuration. The trapezoid cabinet is asymmetric to allow positioning in small arrays. Among the characteristics of the system are elevated angular dispersion, homogenous coverage and a high sensibility.

The speaker has the impedance of 16 ohm allowing many to be coupled together in parallel. Version with 100 V constant voltage line transformer is also available, EDGE25TB black and EDGE25TW white.



Technical Characteristics

System	
System Type	2-way vented enclosure
Frequency Response	125 Hz - 20 kHz (± 6 dB)
Coverage Angle H. (-6 dB)	80° averaged, 1 kHz to 20 kHz
Coverage Angle V. (-6 dB)	65° averaged, 1 kHz to 20 kHz
Directivity Index (DI)	10 averaged, 1 kHz to 20 kHz
Maximum Peak Output	116 dB @ 1m
Input Power Rating	100 W AES, 200 W program
Sensitivity	93 dB SPL (4 V @ 1m)
Nominal Impedance	16 Ω
Constant voltage transformer	optional 100 V EDGE25TB black, EDGE25TW white
Transducers	
Low Frequency Device	2 x 5.25" woofer
High Frequency Device	dome tweeter with SWGH
Mechanical Data	
Construction	monitor taper 20° 15 mm birch plywood with paint finish
Color	black EDGE25PB, white EDGE25PW
Flying Points	2 x M8 - top, bottom 1 x M10 - rear
Dimensions (WxHxD)	17.6 x 46 x 19 cm
Weight	7 kg

Architects' and Engineers' Specifications

The system shall be passive two way with a frequency response from 125 Hz to 20 kHz and an 80°H x 65°V coverage angle. The system shall have a dome tweeter set up on a spherical wave guide in a WTW configuration. The system shall also have two 8 ohm, 5.25" woofers connected in series with the power handling of 100 W AES. The speakers shall have 2 x M8 hanging points positioned on the top and bottom and an M10 attachment point positioned on the rear of the cabinet. The speaker shall be constructed from 15 mm Birch plywood in an asymmetrical trapezoid shape with a monitor angle of 20°. The height shall be 44.5 cm, width 16.5 cm and depth of 17 cm. The system shall be called the PROEL EDGE25P.

3. Technical specifications

Dimensions

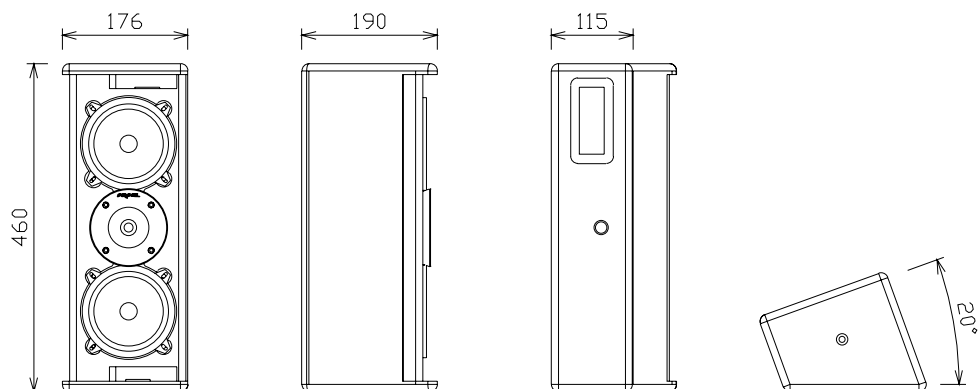

Connections

2 Neutrik Speakon NL4MP connectors in parallel.

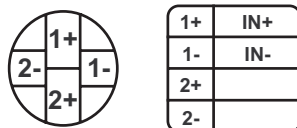

Graphics

Frequency response:

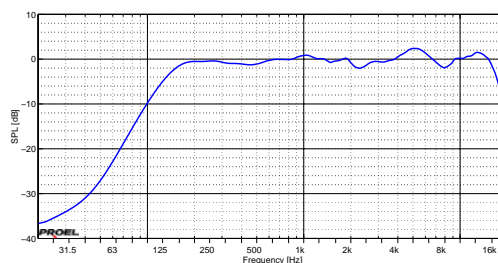

Directivity index:

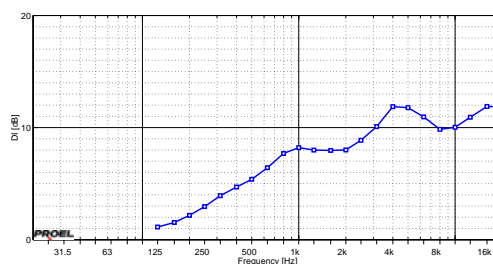

Beamwidth diagram (-6 dB):

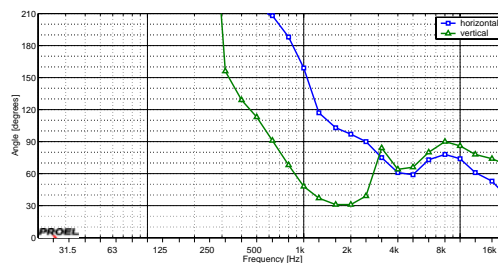

3. Technical specifications

Attenuation map (horizontal):

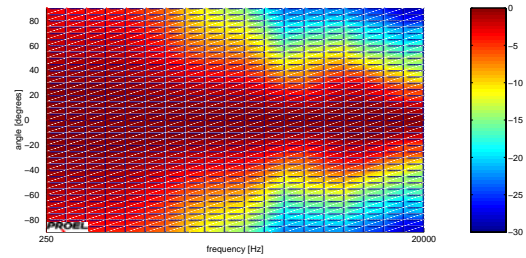

Polar diagram (horizontal):

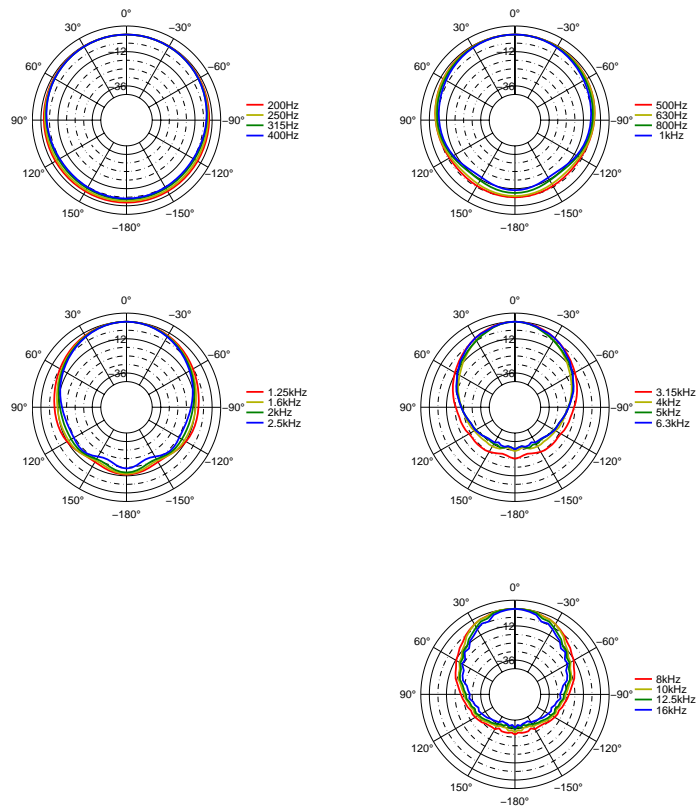

Attenuation map (vertical):

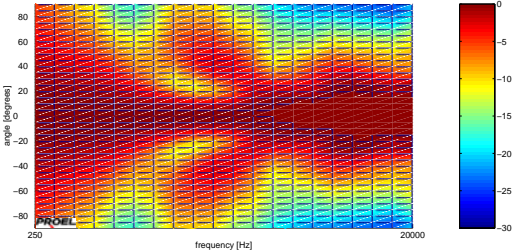

Polar diagram (vertical):



EDGE112SP

Features

- Direct radiating Bass unit
- 12" woofer with a 3" ISV voice coil
- Compact cabinet

Description

The EDGE112SP subwoofer features a 12" woofer with a 3" Interleaved Sandwich Voice coil. The double ventilated die-cast basket has been designed to grant maximum heat dissipation thereby reducing the power compression level. Mechanical excursion is granted by the DSS (Double Silicon Spider) system, which controls the linearity of the system. The EDGE112SP subwoofer is able to handle extremely high powers (400 W AES) both for indoor or outdoor applications. The frequency response reaches 40 Hz with a 125 dB maximum SPL. The EDGE112SP is available with an impedance of 4 ohm (EDGE112SP4) or 8 ohm (EDGE112SP8). This model couples perfectly with the EDGE12CXP, EDGE8CXP and EDGE25P satellites. For a complete system configuration, it is recommended the use of the ASO25 Active System Optimiser, or of the DSO26 Digital System Optimiser. The ideal frequency cut for the EDGE112SP ranges from 125 Hz to 160 Hz.



Technical characteristics

System	
System Type	direct radiation bass-reflex
Frequency Response	39 Hz - 125 Hz (-3 dB)
Maximum Peak Output	125 dB @ 1m
Signal Processing	Proel ASO25, Proel DSO26
Crossover Frequency	from 125 Hz to 160 Hz
Input Power Rating	400 W AES, 800 W program
Sensitivity	96 dB SPL (2.83 V @ 1m)
Nominal Impedance	4 Ω or 8 Ω
Transducer	
Low Frequency Device	12" woofer - 3" voice coil
Mechanical Data	
Construction	15/18 mm birch plywood, internally reinforced with paint finish
Flying Points	5 x M10 - top, bottom, rear
Dimensions (WxHxD)	37 x 46.8 x 46 cm
Weight	24.5 kg

Architects' and Engineers' Specifications

The system shall be a passive subwoofer with a frequency response from 39 Hz to 125 Hz. The system shall be a direct radiating 12" woofer in a bass reflex configuration. The loudspeaker shall be 8 ohm² with a 3" voice coil. The speaker box will be constructed from 15/18 mm Birch plywood with internal reinforcement. The box shall have a rectangular shape, 47 cm high, 37 cm wide and 46 cm deep. The system shall be the PROEL EDGE112SP³.

²For the model EDGE112SP4 substitute 8 ohm with 4 ohm

³Alternatively EDGE112SP4

3. Technical specifications

Dimensions

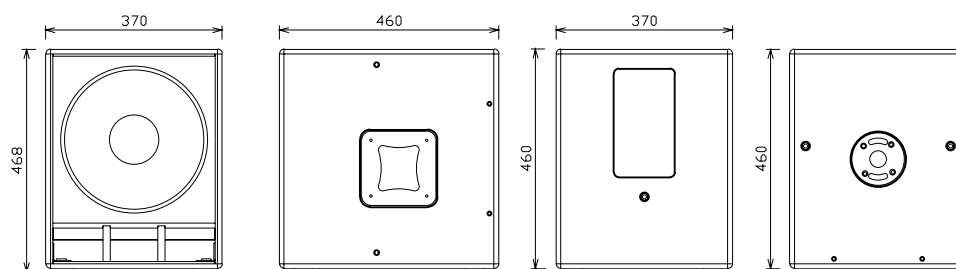

Connections

2 Neutrik Speakon NL4MP connectors in parallel.

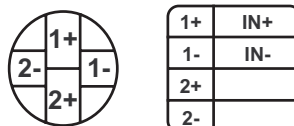

Graphics

Frequency response:

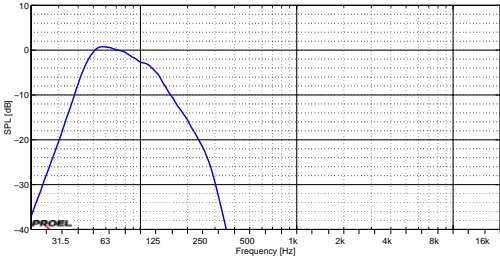

Impedance:

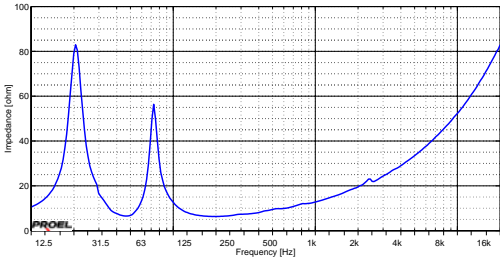

DSO26



Descrizione

The DSO26 Digital System Optimiser is a digital processor giving a high quality audio processing thanks to the double precision signal processing, granting a dynamic range superior to 110 dB. The DSO26 features 2 inputs and 6 outputs⁴ and is designed to operate in the following modes: 2x3 way, 4+2 way, 5+1 way, or 1x6 way with the availability of a *mono sum* output. There are 30 parametrical equalization bands, each allowing gain from +15 to -30 dB in a range of 20 Hz to 20 kHz, with a Q adjustable from 0.4 to 128. All parameters are equipped with adjustable end with frequency steps of 1/36 of octave, a gain increase at steps of 0.1 dB and with 100 adjustments for the Q.

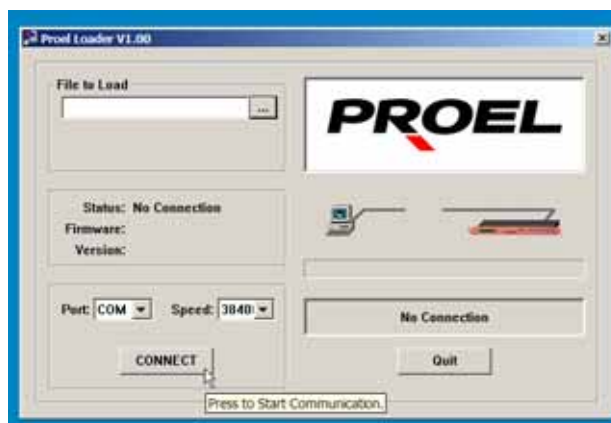

Each parametrical section can be set as a shelving filter. All outputs are equipped with a high performance limiter, with total control on the *attack*, *release* and *threshold* parameters. Each output features a 12, 18 or 24 dB/octave crossover, Butterworth, Bessel or Linkwitz-Riley type. The independent control of each filter allows the creation of asymmetrical crossover bands. Delay lines up to 650ms can be set independently on each output, with an end adjustment

⁴AES-EBU digital inputs and outputs are available on request.

of minimum $2.6\mu\text{s}$. The DSO26 includes presets for the PROEL EDGE systems and allows the saving of personal settings. It also features the possibility to update the software through the RS232 port. The LCD display shows all information about the parameters. It is also possible to display the headroom of both channels through the LED bars. On the web site sound.proelgroup.com it is possible to download the communication software for Windows 9x/Me/2000/XP, updated presets for the EDGE series and the processor manual. We recommend that you read this manual carefully.

Architects' and Engineers' Specifications

The digital processor shall have 2 inputs and 6 outputs. The operating modes shall allow the unit to operate as 2x3 way, 4+2 way, 5+1 way, or 1x6 way with the option of a mono sub output. There shall be 5 parametrical equalization sections for each output. Each input/output shall have: up to 650 ms delay at steps of $2.6\mu\text{s}$, a limiter with attack, release and threshold controls. The input signal level shall be shown by a LED and the parameters displayed on the back-lighted LCD. The digital processor shall feature not less than the following technical specifications: ± 0.5 dB 20 Hz-20 kHz frequency response; dynamics: > 110 dB 20 Hz-20 kHz, not weighted; parametric filters: 30 total digital sections, with gains: +15 dB, -30 dB, at steps of 0.1 dB, central frequencies: 20 Hz-20 kHz, steps of 1/36 of octave, filters Q ranging from 0.4 to 128. Inputs and outputs shall be connected by XLR and be electronically balanced. The processor shall be a 1U 19" rack unit with working voltages ranging from 90 VAC to 240 VAC 50/60 Hz. The digital processor shall be a PROEL DSO26.

3. Technical specifications

Technical specifications

Inputs:	2 electronically balanced
Impedance:	> 10 k Ω
CMRR:	> 65 dB 50 Hz - 10 kHz
Outputs:	6 electronically balanced
Source Imp:	< 60 Ω
Min. Load:	600 Ω
Max. Level:	+20 dBm into 600 Ω
Frequency Resp.:	± 0.5 dB 20 Hz-20 kHz
Dynamic Range:	>110 dB 20 Hz-20 kHz unweighted
Distorsion:	< .02% @ 1 kHz, +18 dBm
Max Delay:	650 ms
Min Step Size:	2.6 μ s
Gain Inputs:	+6 dB to -40 dB in 0.1 dB steps
Gain Outputs:	+15 dB to -40 dB in 0.1 dB steps and mute
Parametric EQ:	5 Sections per output
Gain:	+15 dB to -30 dB, 0.1 dB steps
Freq. Range:	20 Hz - 20 kHz, 1/36 octave steps. (368 positions)
Filter Q / BW:	0.4-128 / 2.5-0.008
Shelving sections:	Low freq.: 20 Hz - 1 kHz High freq.: 1 kHz - 20 kHz Shelf gain: ± 15 dB in passi da 0.1 dB
High and lowpass filters:	Filters: 1 of each per output. Freq. Range HPF: 10 Hz - 16 kHz 1/36 octave steps. Freq. Range LPF: 35 Hz - 22 kHz 1/36 octave steps.
Responses:	Bessel/Butterworth 12-18-24 dB/Oct. Linkwitz-Riley 24 dB/Oct.
Limiters:	1 of each per output
Threshold:	+22 dBu to -10 dBu
Attack time:	0.3 to 90 ms
Release time:	2/4/8/16/32 x Attack time
Display:	2x20 character backlit LCD
Input meter:	2 x 3 point
Output meter:	6 x 3 point
Connectors:	
Inputs:	3 pin female XLR
Outputs:	3 pin male XLR
External:	9 pin DEE (RS232)
Power:	3 pin IEC, 60 to 250 V $\pm 15\%$ @ 50/60 Hz
Consumption:	< 20 watts
Weight:	3.5 kg. Net (4.8 kg. Shipping)
Size:	1.75" (1U) x 19" x 11.8" (44 x 482 x 300 mm) excluding connectors

4 Guide to dimensioning the system

4.1 Sound Reinforcement

The aim of a sound reinforcement system is to cover a specific listening area as uniformly as possible. When the surface to cover is limited and the sound pressure level required is not particularly high, the simplest solution to the problem is the use of a single sound source, or, if desired, the reproduction of a stereophonic image of a couple of sources. As an example, figure 4.1 shows the sound reinforcement of a small listening environment using a couple of EDGE8CXP.

By supplying the loudspeakers with a power of 150 W, it is possible to achieve a uniform coverage of the area with an average sound pressure of about 105 dB. In case the sound reinforcement of larger areas or the achievement of higher pressure levels are required, it is necessary to use loudspeakers featuring a wider angle dissipation diagram or higher power loudspeakers. We quickly achieve the physical limit beyond which it is not possible to realize loudspeakers with the required dissipation and power levels. The only available solution is to increase the number of units being used. Here the problem arises of how to connect the loudspeakers *in arrays* in order to achieve the coverage and pressure required. When combining the effect of two or more sources, due the inevitable temporal distance difference of the sound reaching the hypothetical listener, interaction among the various sources' emissions occurs.

4.2 The phenomenon of the comb filtering

Figure 4.2 shows a situation in which just one loudspeaker is present. This simulation, realized with the EASE software, shows the EDGE25P. The graphic shows the mapping (at an average made across a wide band) of the SPL sound pressure, the delay due to the loudspeaker-listener distance and the trend of

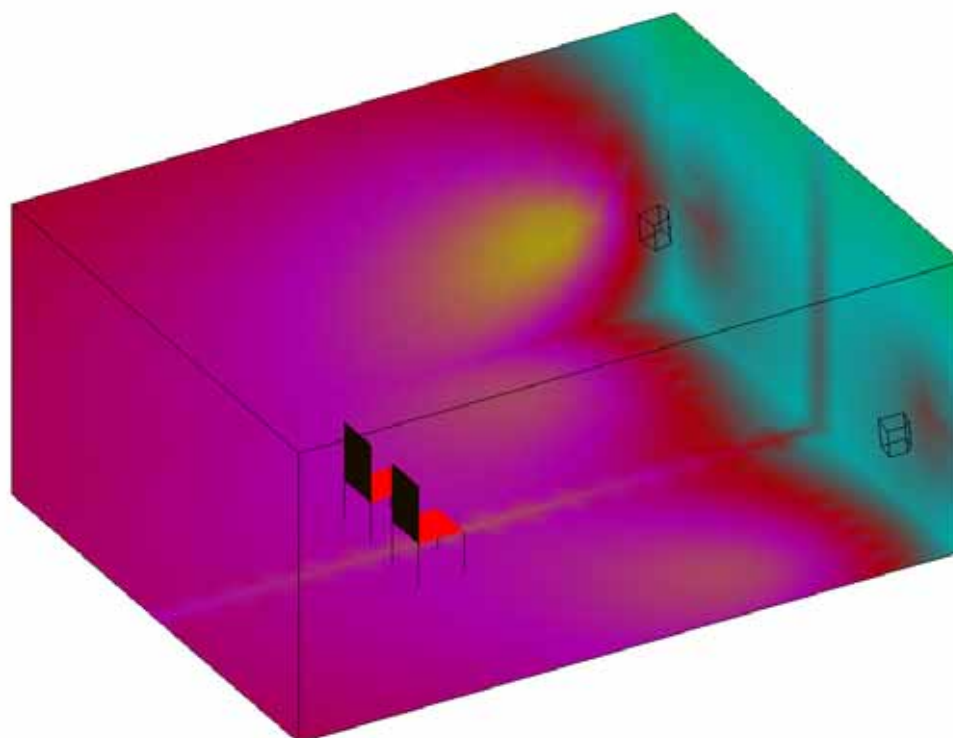

Figure 4.1: sound reinforcement of a small environment

the frequency response in the listening position. It can be seen that the source time of arrival is about 14.5 ms (14.558 ms), corresponding exactly to the source-listener distance of 5m, covered by sound at the speed of 344 m/s. Figure 4.3 gives the situation using two EDGE25P loudspeakers placed apart at a distance of 8 metres. Note the arrival time map. The sound of the second loudspeaker arrives to the listening point about 13 ms after the sound of the first, but at a much lower level. From the SPL level map, it can be seen that the loudspeakers interacting very slightly. The sources are far enough away from each other to allow the delayed sound coming from the second loudspeaker to arrive to the listening point notably attenuated. The frequency response is affected by a phenomenon of *oscillation* which, on the average of a third of an octave, is not appreciable. Figure 4.4 shows the result of the simulation with the loudspeakers placed at a distance of just 2 metres apart. Note that the interaction is intensified both in the SPL level map and even more so for the frequency response.

The phenomenon described above is known as comb filtering, the temporal

The phenomenon of the comb filtering

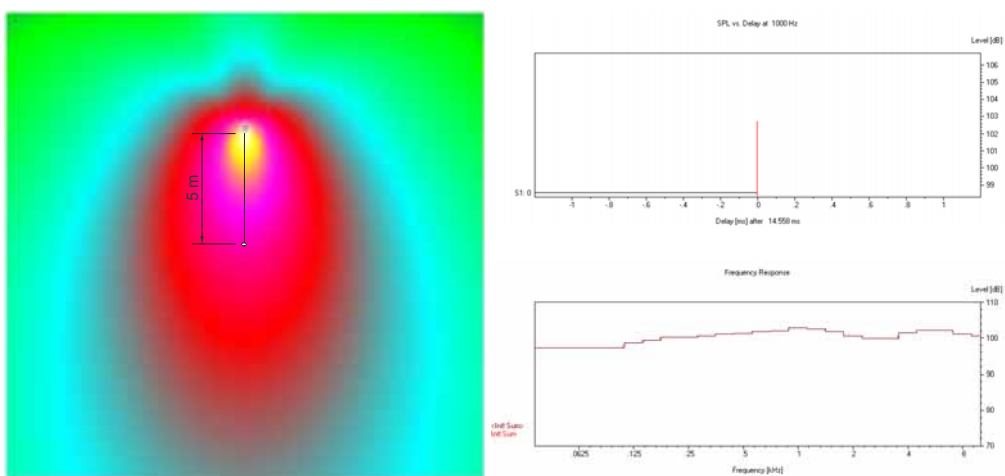

Figure 4.2: One source

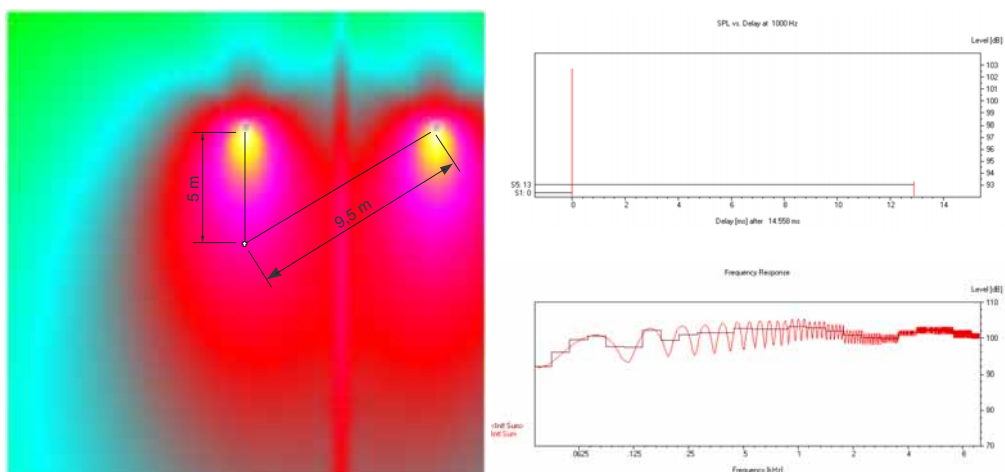

Figure 4.3: Two sources at a distance of 8m

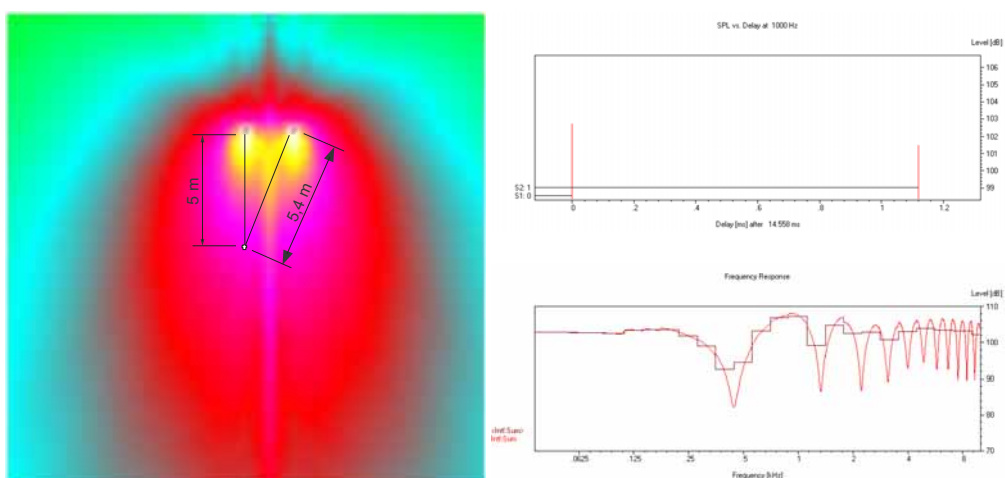

Figure 4.4: Two sources at a distance of 2m

4. Guide to dimensioning the system

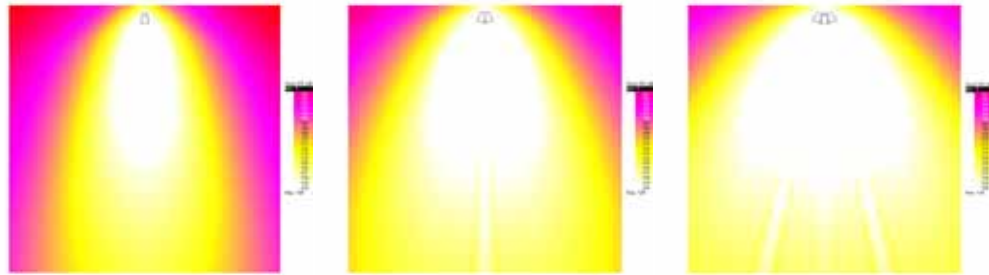

Figure 4.5: Horizontal coverage EDGE212P single, double and triple

difference required for the various sources to arrive to the listening area¹. The frequency separation of the lowest response points due to this phenomenon is inversely proportional to the temporal difference of the arrival of the sources. The intensity of the phenomenon is proportional to the relative pressure level with which the sources arrive to the listener. The more similar the levels of the sources, the wider the oscillations. To minimize the effects of interaction between several loudspeakers it is necessary to make sure that the emission of just one loudspeaker arrives to the listening point, effectively minimizing the relative level coming from the surrounding loudspeakers. This result can be achieved by placing the loudspeakers further apart or by using highly directive loudspeakers. This reflects the two possible approaches generally used for the positioning of the two sources: either by distributing the sound, by assigning each speaker an area to reinforce, or by arraying the speakers to realize a single new source characterized by a higher sound pressure and by a wider dissipation. Both approaches have advantages and disadvantages. In live applications, because of the necessity to realize a correct placing of the sound source, the arraying of loudspeakers is used, whereas in fixed installations it is possible to use the distributed solution.

The EDGE series has been designed for both the creation of arrays for live applications and for distributed sound reinforcement systems. The EDGE212P professional concert system has been designed for typical array use. The average horizontal axis coverage angle of a single element is 50°. The controlled directivity, together with the digital processing of the equipment based on measurements realized in full space, allow the creation of EDGE212P arrays which approximate a single, high powered source and a coverage angle dependent only on the number of speakers used. Figure 4.5 shows the results of three dimensional computer simulations for 1, 2 and 3 EDGE212P set in an array.

¹If the delay in the arrival of the sources exceeds a certain time the two sources are perceived as distinct. At this point, discussions on comb filtering become insignificant.



Figure 4.6: Correct coupling of the EDGE212P

The EDGE212Ps should be arrayed according to the angle naturally created by the trapezoidal cabinet. Avoid dispositioning in straight array with all the loudspeakers in line, parallel with the front cabinet (as shown in figure 4.6).

In situations where an adequate sound pressure level cannot be achieved with a single line of EDGE212P, or when the application requires a very long throw, it is possible to create large arrays by stacking the speakers up to the flying systems mechanical limit of 8 speakers per column. The 25° trapezoidal shape and the extremely safe and easy to use flying mechanism, creating arrays with EDGE212P and EDGE218P subs is simple and fast.

At the web site sound.proelgroup.com, a Microsoft Excel sheet is available for free download, this is a very useful tool, allowing fast and simple EDGE212P and EDGE218P array set up. Alternatively, for a more accurate analysis, it is possible to use the EASE simulation software. EASE models of the EDGE series are available on the same web site.

In arrays featuring several rows of speakers, as in all traditional array systems, there will be an interaction between the emissions of superimposed loudspeakers. It is possible to use this interference effect in a constructive way through the *matching* of the high frequency horns. If EDGE218SP bass units are placed at the edges of the array, a long range coverage system is achieved. Figure 4.7 shows this kind of configuration, used for the reinforcement of a medium/large sized rock concert. Note the upper row of EDGE212P have been positioned upside-down to create the matching of the high frequency horns.

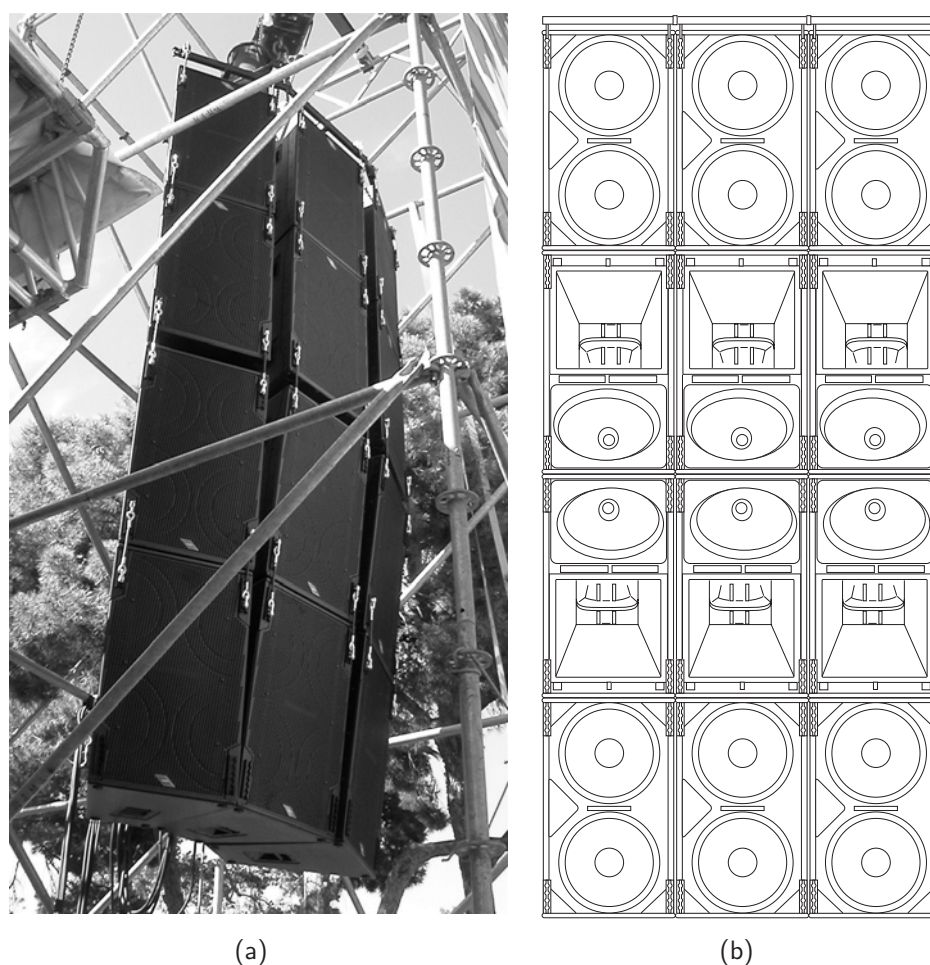

Figure 4.7: EDGE212P and EDGE218SP Array

4.3 Importance of the DSO26 processor

The EDGE212P, EDGE218SP and EDGE121SP concert systems and the EDGE-15CXPB and EDGE12CXP monitors (when operating in bi-amp mode) do not feature passive filtering. In order to work correctly, these models require the use of an external processor for crossover filtering, temporal alignment, equalization and protection of the devices. The PROEL DSO26 digital processor features all of the presets for the EDGE series.

Updated presets can be downloaded from the web site sound.proelgroup.com. The presets for the DSO26 are also compatible with the XTA DP226 processor.

The EDGE series presets have all been designed to achieve the best performance from the systems. The optimisation of the systems achieved by the

4. Guide to dimensioning the system

covers a shorter distance than the top in reaching the listener (position P), it is therefore necessary to delay the emission of the sub to restore the correct temporal alignment. If d is the distance the subwoofer is placed in relation to the theoretical alignment position (the dashed image in the picture), the delay to be set on the processor can be calculated using the following equation:

$$\Delta T = \frac{d}{c}$$

where c is the speed of sound (about 344 m/s). The DSO26 processor also allows the delay to be set directly in metres or feet (please refer to the DSO26 manual for further information).

Example: If the subwoofer is positioned 2 metres forward from the line of satellite units, the equation would work as follows:

$$d = 2 \text{ m}$$

$$\Delta T = \frac{d}{c} = \frac{2}{344} \cong 0,006 \text{ s} = 6 \text{ ms}$$

4.5 Notes on the amplifier power requirements

The technical specifications of the EDGE systems give two different parameters for the power capacity of the loudspeakers; continuous power AES and program power. The AES standard tests the components by submitting them for two hours to a filtered pink noise signal with a 10 step band pass and a crest factor (the relationship between average parameter and peak parameter) of 6 dB. For normal applications, where high levels of power and reliability are required, *it is recommended the use of amplifiers supplying a power equivalent to the AES specifics of the loudspeaker*: in this way, the loudspeakers are sure to operate within their thermal limit. For the applications where using the power capacity in excess is required, it is possible to use amplifiers with a power equivalent to the program power declared in the specifics. In this way, the ability of the systems to reproduce transients is preserved. In this case however, the system must be controlled and managed with particular care to avoid overloading the loudspeakers. The protection function carried out by the DSO26 processor limiter is always active preventing the loudspeakers from being supplied with excessive power for long periods of time (**providing that the gain of the amplifier used is equal to 32 dB. It is necessary to use amplifiers featuring a constant gain of 32 dB to allow the limiter to be effective**). It is always necessary to respect the physical limits of the loudspeaker. Apart from the power capacity problems associated with the thermal

limits, it is necessary to avoid that the loudspeakers are stressed beyond the displacement limits of the cone and beyond the normal operating frequencies. Attention must be taken as it is possible to damage a loudspeaker even when the power level is much lower than its continuous power AES parameter. Distorted signals at very low frequencies can produce cone displacements beyond the speakers physical limits.

4.6 Power lost by the cables

As well as the correct amplifier power specifics, it is necessary to take account of the fact that part of the power is dissipated along the cables connecting the amplifiers to the loudspeakers. The following table shows the power loss related to the load and type of cable used.

cable lenght [m]	cable gauge	power loss 8Ω[%]	power loss 4Ω[%]	power loss 2Ω[%]
5	12 AWG/4 mm ²	1	1	3
	14 AWG/2,5 mm ²	1	2	4
	16 AWG/1,5 mm ²	2	3	6
10	12 AWG/4 mm ²	1	3	5
	14 AWG/2,5 mm ²	2	4	8
	16 AWG/1,5 mm ²	3	6	12
15	12 AWG/4 mm ²	2	4	7
	14 AWG/2,5 mm ²	3	6	11
	16 AWG/1,5 mm ²	5	9	17
20	12 AWG/4 mm ²	3	5	10
	14 AWG/2,5 mm ²	4	8	14
	16 AWG/1,5 mm ²	6	12	21

5 Guide to flying the EDGE system

This section is dedicated to the suspension of the EDGE212P and EDGE218SP systems. The other products of the series EDGE15CXPB, EDGE8CXP and EDGE25P are equipped with built in flying points for eye-rings¹ which allow suspension for fixed installations. Accessories are available for these products for stand, wall and truss mounting. For a more detailed description of these products, refer to the next chapter *Edge Accessories*.

5.1 The flying system

The EDGE212P and EDGE218SP loudspeakers are designed to be flown in arrays of many different dimensions, through the flying system which has been engineered for a quick, flexible and secure use. Each loudspeaker features front and rear flying-tracks which are recessed in the frame of the cabinet. Loudspeakers can be connected into columns by fitting the AC172P steel cables and the AC172E connecting hinges securely in the flying-tracks.

These columns are flown by connecting them, by way of cables, hinges and flying-tracks, to the dedicated flying bar. The flying bar is composed of as many elements (code KPTED1218) as columns to be suspended, with a maximum of 4 rows. Each column can contain up to 8 loudspeakers.

The modularity of the flying bar gives the system great flexibility. Due to the large number of possible configurations given by the loudspeaker connection points and the modularity of the flying bar, it will be necessary to use the spreadsheet (supplied with this manual), to simulate the array configuration, calculate the centre of gravity therefore the flying points to be used for the correct set up of the system.

¹For the EDGE15CXPB, EDGE12CXP and EDGE8CXP, for the eye-rings are M10, the EDGE25P features both M8 and M10 eye-rings threads.

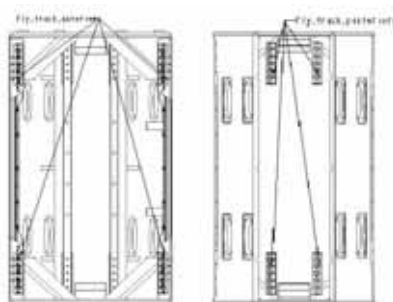

Figure 5.1: Inner frame of the loudspeaker

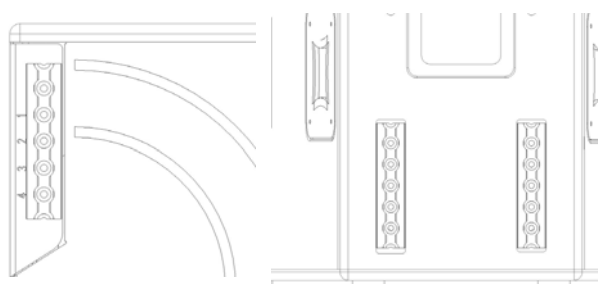

Figure 5.2: Detail of the front and rear flying-tracks

5.2 Material used for flying the system

The EDGE212P and EDGE218SP concert speakers feature the flying-track system for suspension. Figure 5.2 shows in detail the front flying-track with the numbered of connection points. These should be connected using the for steel connecting cables. Also shown are the two rear flying-tracks. Notice here the absence of numbering. This is because the connection position of the rear connecting hinges is fixed.

The materials available for the realization and the suspension of arrays are:

- The single KPTED1218 elements of the flying bar including a shackle with a 22 mm pivot diameter
- The KPTEDTR1 and KPTEDTR2 lifting bars for the uniform redistribution of the load
- The AC180 chains with lifting hook

- The AC172P rear connecting hinges
- The AC172E connecting cables

The KPTED1218 flying bar elements

The KPTED1218 is the basic element of the EDGE systems flying bar. The element features front and rear flying-tracks for the connection of the loudspeakers and telescopic braces for the cross connection of the single KPTED1218 elements of the flying bar. The telescopic braces are fitted using numbered connecting points. By using the same position both for the front and the rear brace, the angle formed between the columns of the array will be 25°. In the table below, the angles formed in relation to the different mounting positions of the braces are shown.

		<i>front braces position</i>					
		<i>1</i>	<i>2</i>	<i>3</i>	<i>4</i>	<i>5</i>	<i>6</i>
<i>rear braces position</i>	<i>1</i>	25,0	30,7	35,6	39,1	43,6	47,9
	<i>2</i>	19,2	25,0	30,0	33,6	38,2	42,7
	<i>3</i>	14,0	19,9	25,0	28,8	33,5	38,1
	<i>4</i>	10,1	16,1	21,2	25,0	29,8	34,5
	<i>5</i>	5,1	11,1	16,3	20,1	25,0	29,8
	<i>6</i>	0,0	6,0	11,3	15,2	20,1	25,0

Table 5.1: Angle between the columns of the array

The position of the extendable brackets, as well as changing the angle, can be used to alter the distance between the columns of the array: the longer the position of the bracket, the further apart the columns will be. For acoustic reasons, it is recommended to use corresponding holes for both the front and rear telescopic brackets in order to keep the angle between the columns at 25° and to minimize the distance between the columns of the array.

KPTEDTR1 and KPTEDTR2 lifting bars

The KPTEDTR1 and KPTEDTR2 lifting bars allow the lifting of 2, 3 or 4 array columns, each composed of up to 8 loudspeakers in a simple, compact and safe way. The use of these bars gives the correct distribution of the load across the various elements of the flying bar. The KPTEDTR2 bar features symmetrically numbered holes for connection to the KPTED1218 elements by means of 22mm shackles and has a central hole for lifting. The KPTEDTR1 bar features two groups of outer symmetrical numbered holes and a central group

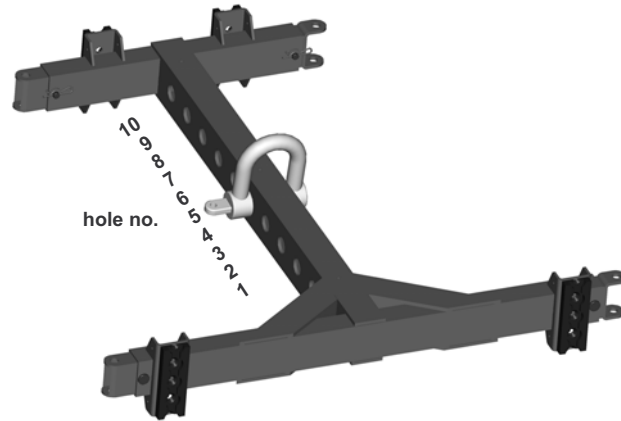

Figure 5.3: KPTED1218 flying bar element

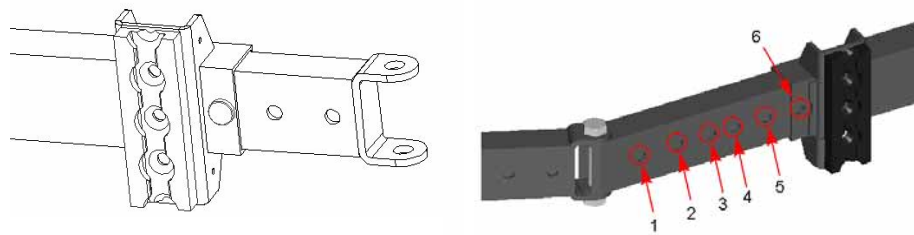

Figure 5.4: Details of the telescopic brackets

of holes for the connection to the KPTED1218 elements and a central hole for lifting. In the case of a 3-column configuration (as shown in figure 5.6), the KPTEDTR1 is connected directly to the KPTED1218 elements by means of the 22mm shackles. In the case of a 4-column configuration, the KPTEDTR1 is connected to two sets of KPTEDTR2 which in turn are connected to the KPTED1218 elements of the flying bar (as shown in figure 5.7).

AC180 chains with hooks

In the simplest of situations, with a maximum of 3 columns comprised of up to 4 loudspeakers per column, it is possible to use the AC180 hooked chains to lift the flying bar. When connecting the chains to the single KPTED1218 elements, it is necessary to take care to ensure the correct distribution of the load

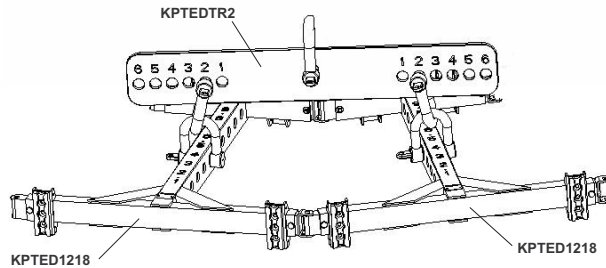

Figure 5.5: Two-column configuration

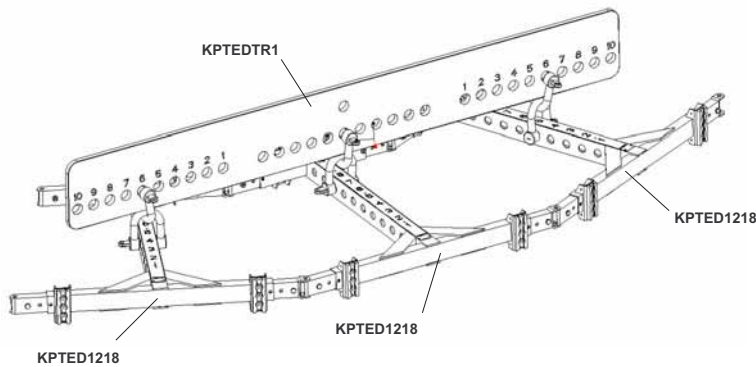

Figure 5.6: Three-column configuration

among the chains. The maximum load capacity of the AC180 hooked chains is 2100 kgf (20580 N). **It is recommended that the AC180 system be used exclusively by personnel with excellent knowledge and experience of the procedures required in the lifting of array systems.**

AC172P connection hinges

The AC172P connection hinges allow the rear connection of the loudspeakers in vertical arrays, permitting perfect alignment even after the possible rotation of the speakers. The maximum load capacity of the AC172P hinges is 500 , (4900 N) with the strength directed along the axis of the track. The hinges are positioned in the flying-tracks of both the loudspeakers and the flying bar.

5. Guide to flying the EDGE system

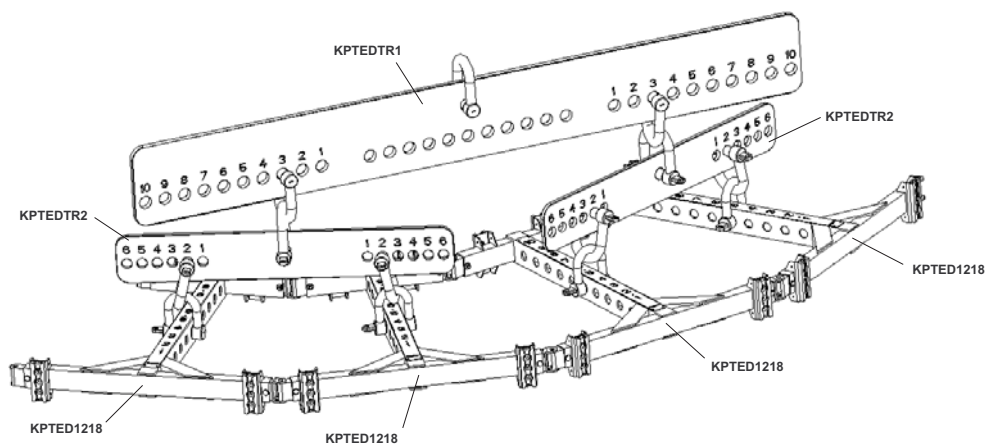

Figure 5.7: Four-column configuration



Figure 5.8: AC180 chains with hooks

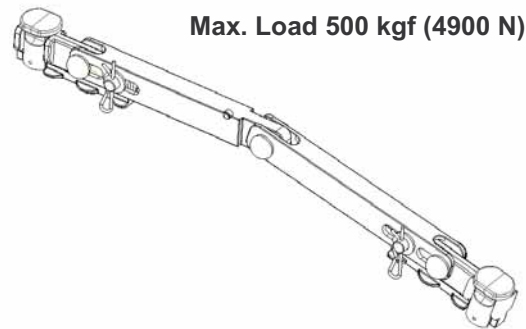

Figure 5.9: AC172P connection hinges



Figure 5.10: AC172E connection cables

AC172E connection cables

The AC172E steel connecting cables are used for the front connection of the loudspeakers in column array. The maximum load capacity of the AC172E cables is 500 kgf (4900 N) with the strength directed along the axis of the track. The hinges are positioned in the front flying-tracks of the loudspeakers and the KPTED1218 flying bar. By choosing the point of connection in the flying-track it is possible to adjust the vertical angle referent to the single loudspeaker in steps of approximately 2°.

5.3 Load limits

The load limits reported in the present manual have been determined on the base of project calculations carried out by finite element modelling analysis and subsequently validated by empirical tests of load capacity. The flying bar realized with the KPTED1218 elements allows lifting maximum 8 loudspeakers per column in 4-column, 3-column and 2-column configurations (see figure 5.11) only if using the KPTEDTR1 and KPTEDTR2 bars for the load distribution.

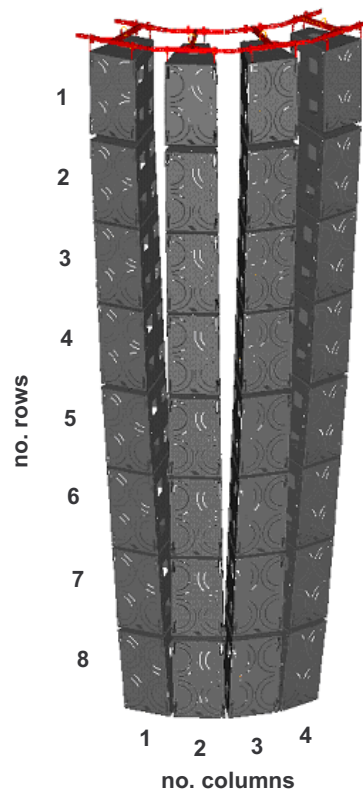

Figure 5.11: Maximum possible configuration

In case in 2 or 3-column configurations it is possible to use the AC180 hooked chains, but with a maximum of 4 loudspeakers per column.

With regards to the configuration of the single columns, figure 5.12 shows four configuration types.

To create configurations different from these illustrated, it is necessary to calculate the centre of gravity of the array, using the supplied spreadsheet, ensuring that it falls inside the central section of the flying bar and inside the interval of the available holes. If these parameters are not confirmed, a correct positioning of the loudspeakers will not be guaranteed and therefore the load limits of the system will not be verified. The configuration which applies the most stress to the front part of the flying bar is 8 EDGE212P in a column with a relative angle of 0° for each loudspeaker. The configuration which applies most stress to the rear part of the flying bar is with 8 EDGE212P with an angle of 0° for the first two loudspeakers, 2° for the third and fourth and 6° for the fifth, sixth, seventh and eighth loudspeaker.

The technical specifications supplied here may be subject to change. Up-

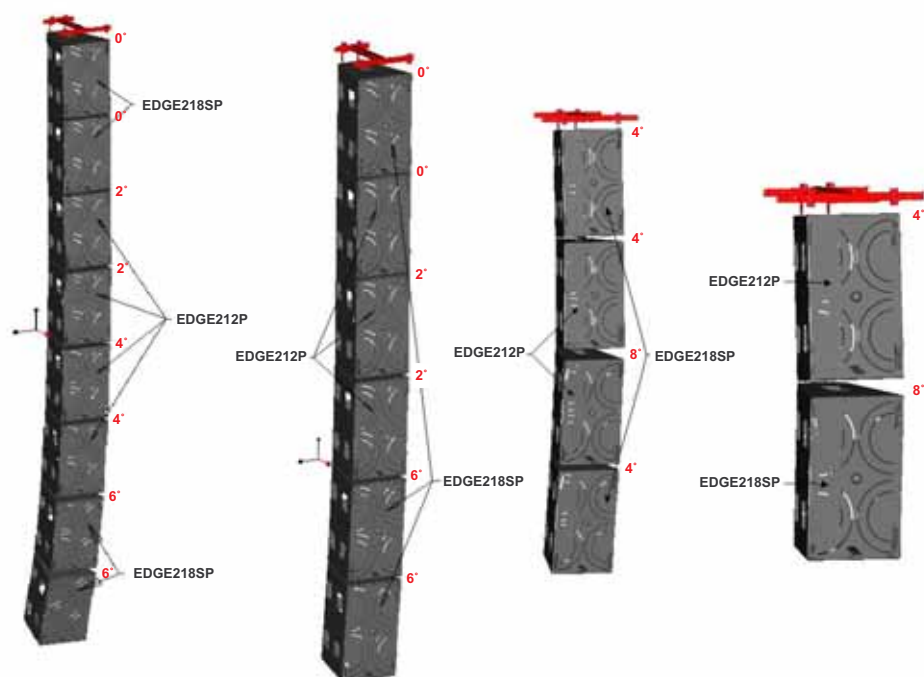

Figure 5.12: Various column types

dates will be made available at the web site sound.proelgroup.com and it is advised that the user of the EDGE systems check for updates at regular intervals.

5.4 Safety information

In spite of the fact that the present manual contains useful information for the flying of loudspeaker arrays, in particular to the EDGE systems, it is not possible to provide exhaustive information of the subject in this manual. The system should be flown exclusively by skilled and trained personnel.

The installer of the system must ensure, under his own responsibility, the limits and lifting procedures of the structures where the array is to be flown. Improper or incorrect use of a flying array system can cause serious damage to people and objects.

The material produced by Proel has been designed and tested to exclude the possibility of structural damage in normal use, providing that the materials

5. Guide to flying the EDGE system

are inspected at regular periods. Special care has been taken with regards to the choice of materials and manufacturing procedures utilised to grant a high level of safety. All parts have safety margins which are adequate when used in compliance with the specifics described in this manual.

The configurations suggested in this manual and by the spreadsheet supplied have been created with both computer modelling analysis and actual operative tests.

Proel recommends flying the loudspeakers respecting all the national, federal and local rules.

Always ensure that the hooks and connectors are securely fastened in the suspension bars and that safety fasteners are housed correctly before lifting any loudspeaker.

5.5 Inspection and maintenance

Every time the EDGE system is to be suspended it is necessary to carefully inspect all of the materials and items, including the upper structures where the system is to be flown. This must be done to exclude all signs of wear, aging, buckling, corrosion and/or damage. The expected duration of the elements of the KPTED1218 flying bar, considering a frequency of use of 20 times a month and respecting the limitations described in section 5.3 of this manual, is 15 years. It is necessary for the system to be inspected yearly by qualified personnel on the behalf of Proel in order to check the general state of the structure (especially the integrity of the welded points) and in if necessary arrange maintenance. The inspections should be carried out in the following order:

- identification of the lifting equipment;
- check of the conditions of the components and the devices, with reference to damage, wear, corrosion or any other change;
- functional test of the mechanisms;
- examination of the welding points and evaluation on the presence of possible cracks;
- examination of the chains and evaluation on the presence of possible elongations, wear or cracks;
- test of the connecting pivots and hooks and thus evaluation on the presence of possible buckling, wear or cracks;

If anomalies or faults are found with the components, it will be necessary to replace the faulty parts with original Proel pieces.

5.6 Responsibility

Although the system has been designed to be simple and quick to set up, this does permit the use of the flying system by untrained personnel and without a previous and careful reading of this manual. Proel recommends that the EDGE systems are suspended respecting all national, federal and local laws. The user is held totally responsible for checking that the EDGE flying system is compliant with the local laws and rules. The user is held totally responsible for making sure that the system is installed correctly, in compliance with the system load capacity limits and the indications written in this manual. The product must be installed by trained personnel and never exceeding the load capacity limits, strictly following all of the indications supplied in this manual. All non Proel parts used are responsibility of the third party. Technical specifications can be subject to changes without notice, the user is held responsible for making sure that the system is suspended in compliance with the indications contained in this document and successive updates. The system composed by the KPTED1218 modular flying bar and corresponding accessories can be used as lifting system exclusively for Proel EDGE212P and EDGE218SP sound systems and not for systems of a different brand or model. Proel declines all responsibility for damages to third parties caused by lack of maintenance, tampering, improper use or installation carried out without following the safety rules. Such improper use will also annul of the terms of guarantee.

5.7 Set up operation

Simulation of the desires configuration with the Excel spreadsheet supplied

The spreadsheet allows the simulation of arrays of a maximum dimension of 4 columns each with 8 rows of speakers by calculating the position of the centre of gravity², suggesting graphically the connection points for each single com-

²The influence of the speaker cables is not taken into account for the calculation. It is necessary to distribute the weight of the cables as close to the centre of gravity as possible to avoid the array resulting in a different position from the one simulated. The weight of the cables may make it necessary the use different connecting points.

5. Guide to flying the EDGE system

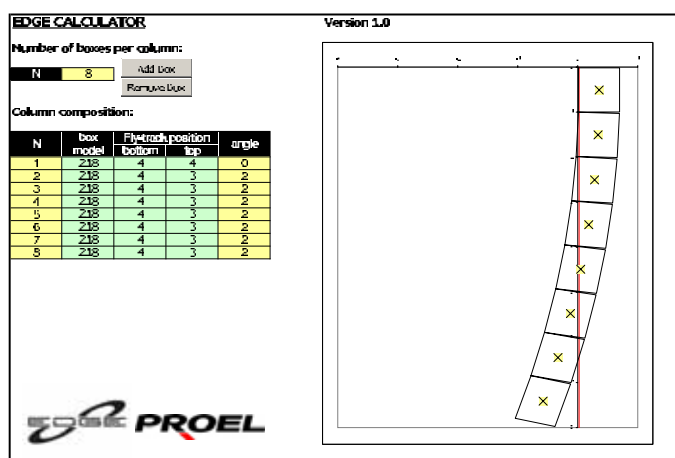

Figure 5.13: Spreadsheet

ponent and advising on eventual physical limits of the proposed array³. In this case, it will be necessary to extract progressively the extendable brackets of the KPTED1218 until contact between the speakers is avoided. The spreadsheet also provides quick estimation of the vertical coverage of the array. For a more detailed simulation of the coverage of the array, it is necessary to use an electro-acoustic prediction software. At the web site sound.proelgroup.com the models of the whole EDGE line are available for the EASE programme. The updated versions of the spreadsheet can be downloaded at the web site sound.proelgroup.com along with the users guide free of charge. Complex configurations not contemplated in the spreadsheet can be realized only if previously approved by the Proel technical department.

Composition of the flying bar starting from the single KPTED1218 EDGE modules

The flying bar is made by connecting the single KPTED1218 elements by means of the extendable brackets. One KPTED1218 element is required for each column of loudspeakers.

There are 6 different possible positions⁴ on the extendable brackets of the KPTED1218 element.

³When building speaker columns with a large vertical slope, the loudspeakers in the array may touch causing compression. In this case, it is necessary to space the columns by extending the bracket arms of the flying bar elements.

⁴To respect the load capacity limits of the flying bar in the case of 3 or 4 columns, it is possible to use only 5 positions of the extendable brackets. In this case, the maximum extension of the braces is not possible.

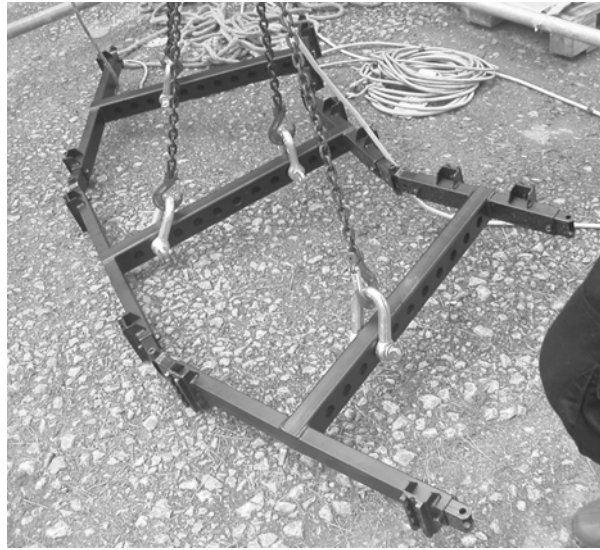

Figure 5.14: Flying bar realized with 3 KPTED1218 elements

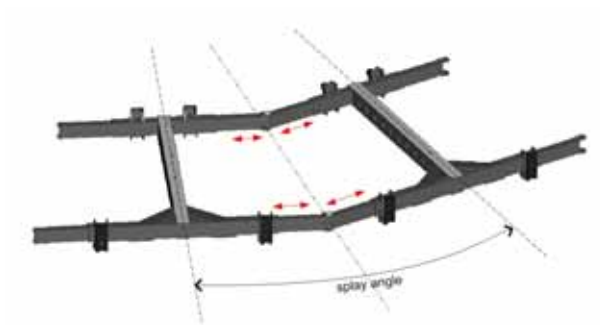

Figure 5.15: Coupling angle of the flying bar elements

The angle and the distance between the columns of loudspeakers can be adjusted by changing the position of the extendable bracket. To maintain a constant 25° angle⁵ between the columns, it is necessary to use the corresponding holes for both the front and rear extendable brackets, as shown on table 5.1.

⁵The 25° angle is necessary for a correct acoustic functioning of the EDGE212P. The use of different angles may create an incorrect performance of the system, due to incorrect emission superposition. For this reason, it is necessary to minimize the distance between the columns of the array as much as possible.

Connecting the flying bar to lifting device

The connection point of the array must be as close to the centre of gravity as possible. The coupling may be realized in various ways depending on the number of columns of the array:

Single column: In this case it is sufficient to lift the flying bar (composed of just one KPTED1218 element) by connecting the lifting device to the hook closest to the centre of gravity.

2 columns: In this case it is necessary to lift the flying bar (composed of two KPTED1218 elements), by the respective coupling points as suggested by the spreadsheet, using the KPTEDTR2 connecting bar. It is necessary to attach the connecting bar using the holes of the same number and as close as possible to the centre of the two KPTED1218 elements of the flying bar. If you wish to realize an array with a maximum of 4 loudspeakers for each column, it is possible to lift the flying bar by means of AC180 hooked chains.

3 columns: In this case it is necessary to lift the flying bar (composed of three KPTED1218 elements), by the coupling points suggested by the spreadsheet, using the side holes of the KPTEDTR1 connecting bar, of the same number for the two KPTED1218 outer elements and the central hole for the KPTED1218 central element. If you wish to realize an array with a maximum of 4 loudspeakers for each column, it is possible to lift the flying bar by means of AC180 hooked chains.

4 columns: In this case the flying bar is composed of 4 KPTED1218 elements. It is necessary to consider the elements like two independent pairs and therefore first carry out the operations indicated for the case of 2 columns and then connect the two external shackles of the KPTEDTR1 bar, using the holes identified by the same number and as close as possible to the central upper holes of the KPTEDTR2 bars.

Connecting the first line of the loudspeaker columns

Place the single loudspeakers underneath the lifted flying bar in a way that allows the connection of the AC172P hinges and the AC172E cables. Connect the AC172P hinges to the upper rear flying-tracks of the KPTED1218 elements of the flying bar and in the lower part of the loudspeaker upper rear flying-tracks. An image of the correct mounting position is shown in figure 5.17.

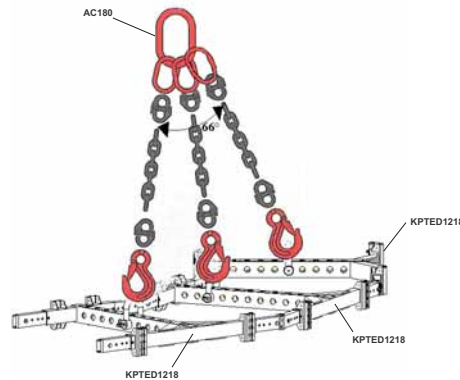

Figure 5.16: Lifting 3 columns with the AC180 chains



Figure 5.17: Correct position of the rear hinges in the connection of the loudspeakers to the flying bar

Next, connect the AC172E cables in the upper front flying-tracks of the KPTED1218 flying bar and in the loudspeaker upper front flying-tracks choosing the hole which refers to the required angle of loudspeaker. The angle parameter is proportional to the number of points left free in the flying-track according to the following formula:

$$\text{angle} = 2^\circ \times \text{number of free points}$$

The points are also numbered from 1 to 4, an alternative formula for the calculation of the angle is:

$$\text{angle} = 2^\circ \times (4 - \text{point number})$$



Figure 5.18: Front cable position for the connection between the loudspeakers and the flying bar

The correct connection of the front cables is shown in the figure 5.18. Please note that two points are left free, therefore the angle of the first loudspeaker will be 4° .

Both the cables and the hinges are fitted with a security lock. When mounting, it is necessary that they are inserted into the loudspeaker track with the security lock pulled back (open). Once the required hole has been reached, to ensure the coupling it good enough for the lock to close. Make sure that all of the connection cylinders are perfectly placed in the corresponding housings. To disconnect, the procedure should be reversed, unlock the catch by pulling back the locking mechanism and letting the cable/hinge slide out of the flying-track.

Connecting subsequent loudspeakers

Place the single loudspeakers under the lifted array allowing the correct coupling of the AC172P hinges (see figure 5.20) and of the AC172E cables. Connect the AC172P hinges to the lower points of the rear flying-tracks of the loudspeaker. Connect the AC172E cables to the front flying-tracks of the loudspeaker choosing the coupling points according to the angle required between the loudspeakers. The parameter of the angle is proportional to the number of the points left free both in the upper loudspeaker flying-track and in the corresponding lower one, according to the formula:



Figure 5.19: Test of the correct placing of the connection cylinders



Figure 5.20: Correct positioning AC172E hinges

$$\text{angle} = 2^\circ \times \text{number of free points in both tracks}$$

The points are numbered from 1 to 4, an alternative formula for the calculation of the angle is:

$$\text{angle} = 2^\circ \times (8 - \text{upper point number} - \text{lower point number})$$

Make sure that all of the connection cylinders are perfectly placed in the corresponding housings.

5. Guide to flying the EDGE system



Figure 5.21: Array cabled and ready to be lifted

At this point, speaker cabling can be carried out. In general, it is recommended to attach the cables to the flying bar and then drop them down on the array, in a way that the cables do not weigh on the Speakon connectors and not influence the position of the array. It is necessary to take account of this fact when calculating the length of the speaker cables.

If the array requires a further row of loudspeakers, repeat the procedure described above. Once the array is completed it is recommended to connect ropes to the lower loudspeakers of the array to prevent movement and rotation. Connect the metal structures (including the hoist and the lifting device) to a single ground point.

Dismantling the array

The array should be dismantled following the above procedure should be reversed. Lower the array to the ground, unlock the connecting cables and hinges of the lowest line of loudspeakers and remove all connections. Lifting the array slightly, the line of loudspeakers on the ground is free to be removed. Proceed-

ing in this way, the whole array can be dismantled very quickly.

5.8 Operations which should be carried out

- Inspect the suspension equipment before each use
- Respect all local security laws and rules regarding installations,
- Hang the system on the connecting points suggested by the spreadsheet,
- Have the system installed exclusively by trained personnel, having carefully read this manual and appropriate updates
- Make sure that the connection cylinders are perfectly fitted in the corresponding housings of the flying-track
- Make sure that the lifting source (hoist or other) has a higher or equal load capacity than the load to be lifted

5.9 Operations which should be avoided

- Never fly anything before having read this manual
- Never use unqualified personnel
- Never exceed the load capacity limits
- Never use non original replacement parts
- Never use damaged or worn materials
- Never use a lifting speed faster than 4m/min



Figure 5.22: Complete array positioned

6 EDGE Accessories

Installation accessories

The EDGE15CXPB, EDGE12CXP, EDGE8CXP, EDGE25P models feature threads for M10 and M8 (only for the EDGE25P) eye-rings for suspension in fixed installations. Installations should be carried out by trained personnel.

- **AC171** Steel cable: 75cm long
- **AC172** Steel cable: 150cm long
- **AC173** Anchor shackles for AC171/AC172
- **AC169A** galvanized black eye-ring for AC173
- **KPTED25B** (black) - **KPTED25W** (white) EDGE25P wall mounting bracket
- **KPTED8B** (black) - **KPTED8W** (white) EDGE8CXP wall mounting bracket
- **KPTED8SB** (black) - **KPTED8SW** (white) EDGE8CXP wall mounting bracket with swivel joint
- **PLH300** Coupler for truss installation
- **PLKP182FL** Accessorio per montaggio su stativo EDGE25P

Storage and transport accessories

To ensure the maximum lifespan of the products in the EDGE series, strong, resistant covers are available, as are special solutions for the transport of the systems.

- **COVERE218** Padded cover for EDGE212P and EDGE218SP



Figure 6.1: Case for transport for 2 x EDGE15CXPB or EDGE12CXP monitors



Figure 6.2: Skate for EDGE212P and EDGE218SP

- **COVERE121** Padded cover for EDGE121SP sub
- **COVERE15** Padded cover for EDGE15CXPB monitor
- **COVERE12** Padded cover for EDGE12CXP monitor
- **COVERE8** TNT cover for EDGE8CXP
- **EDGESKATE** Skate for EDGE212P and EDGE218SP
- **CP023A03** Case for transport for 2 x EDGE15CXPB monitors
- **CP023E03** Case for transport for 2 x EDGE12CXP monitors

7 Typical applications

The EDGE systems have been designed to be extremely modular. The following chapter, shows an example of some of the typical applications for live concert systems and fixed installations. These are just few of the many possible configurations of the EDGE system.

7. Typical applications

7.1 Basic concert system

The 50° horizontal coverage angle of the EDGE212P implies that at least 2 loudspeakers for each side will be required for a concert live system. In the following example, EDGE212P tops are coupled with the EDGE218SP flying subs to create a system which can be both built of the wings of a small stage, and suspended using the EDGE flying bar and accessories. The high output level and the controlled directivity together with the compact shape make this system ideal for installation in clubs and pubs as the FOH system.

Block diagram

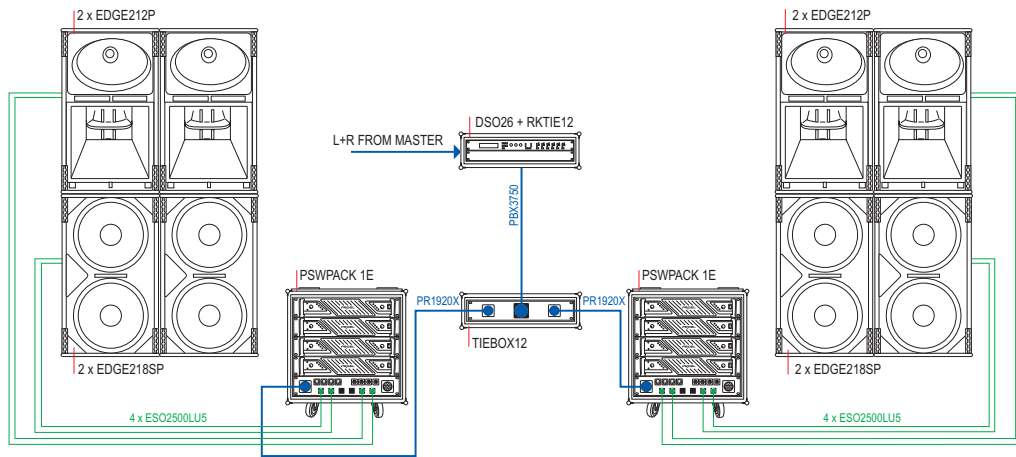

PSWPACK 1E	amplifier rack for 2 x EDGE212P + 2 x EDGE218SP
PSW2600	parallel mode (SUB1)
PSW2600	parallel mode (SUB2)
PSW2600	stereo mode (LO1+HI1)
PSW2600	stereo mode (LO2+HI2)
CRK401	output/signal panel MIX+XLR/SPEAKON
CSP9932	power panel 32A plug
CP047C02	10 U professional rack case

CAD simulation

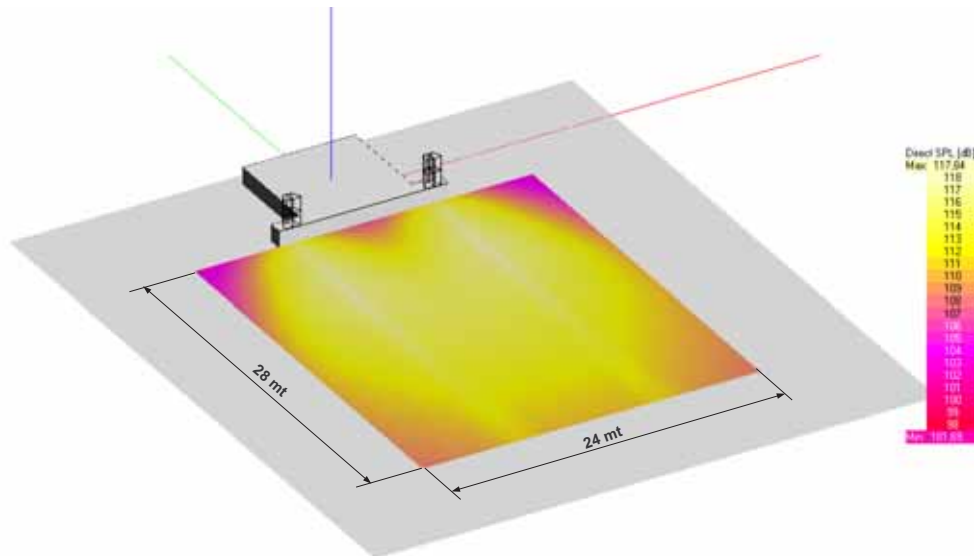

Systems	4 x EDGE212P 4 x EDGE218SP
Power Amplifiers	8 x Proel PSW2600
Signal Processing	1 x Proel DSO26
Sound Level	112 dB average on 28 x 24 mt area
Estimated Audience	2500 - 3000 people
Total amp. continuous power	11200 W

7. Typical applications

7.2 Basic concert system with a floor mounted sub

As an alternative to the basic system described above, it is possible to use the EDGE121SP 21" floor mounted subs in place of the EDGE218SP flying subs. At least 3 of these subs are recommended for each side to achieve the correct tone balance.

Block diagram

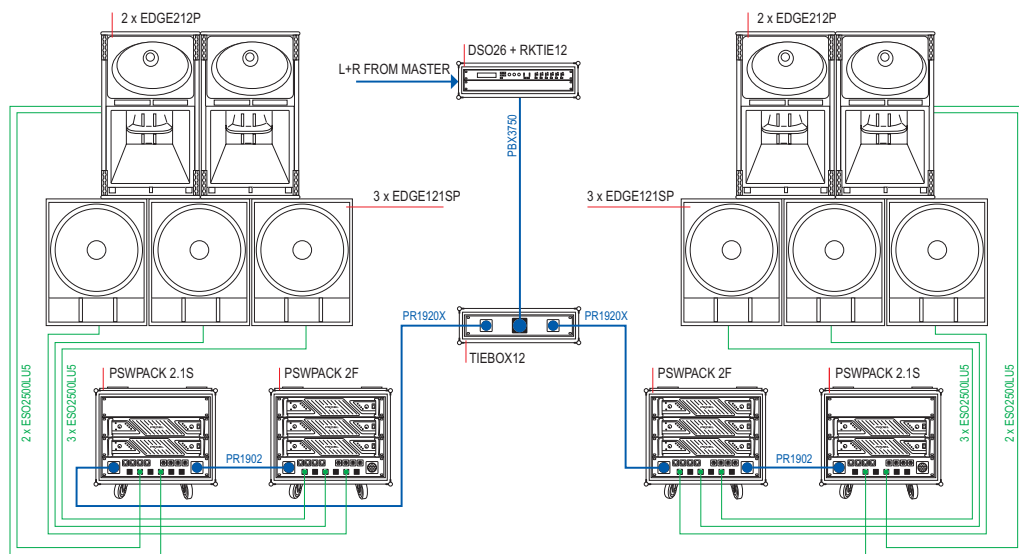

PSWPACK 2.1S		amplifier rack for 2 x EDGE212P
RK2L	rack panel 2 U	
PSW2600	stereo mode (LO1+HI1)	
PSW2600	stereo mode (LO2+HI2)	
CRK401	output/signal panel MIX+XLR/SPEAKON	
CSP99	power panel 16A plug	
CP047B02	8 U professional rack case	

PSWPACK 2F		amplifier rack for 3 x EDGE121P
PSW2600	bridge mode (SUB1)	
PSW2600	bridge mode (SUB2)	
PSW2600	bridge mode (SUB3)	
CRK401	output/signal panel MIX+XLR/SPEAKON	
CSP99	power panel 16A plug	
CP047B02	8 U professional rack case	

CAD simulation

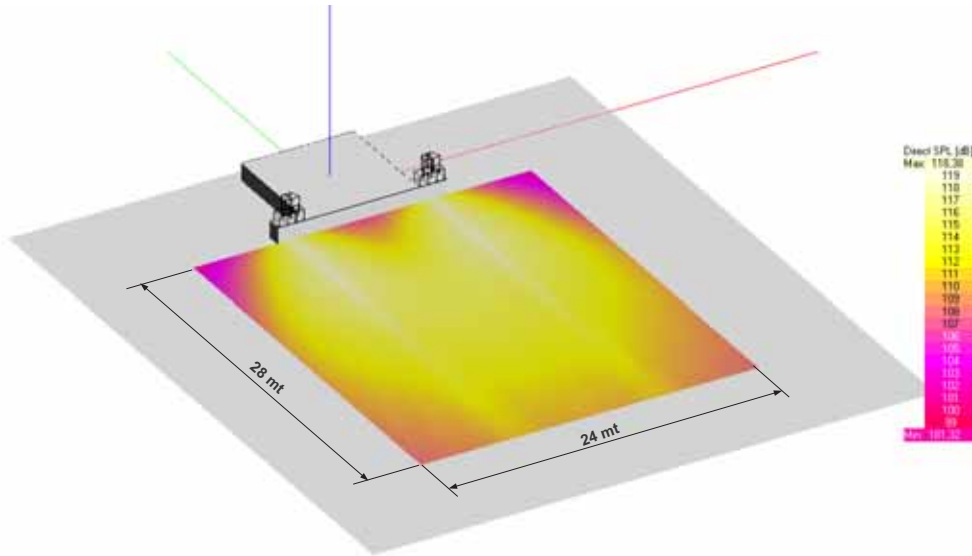

Systems	4 x EDGE212P 6 x EDGE121SP
Power Amplifiers	10 x Proel PSW2600
Signal Processing	1 x Proel DSO26
Sound Level	112 dB average on 28 x 24 mt area
Estimated Audience	2500 - 3000 people
Total amp. continuous power	17600 W

7. Typical applications

7.3 Medium size concert system

By adding one top and one sub to the solution described above, it is possible to obtain a system with a wider coverage angle and a higher output level.

Block diagram

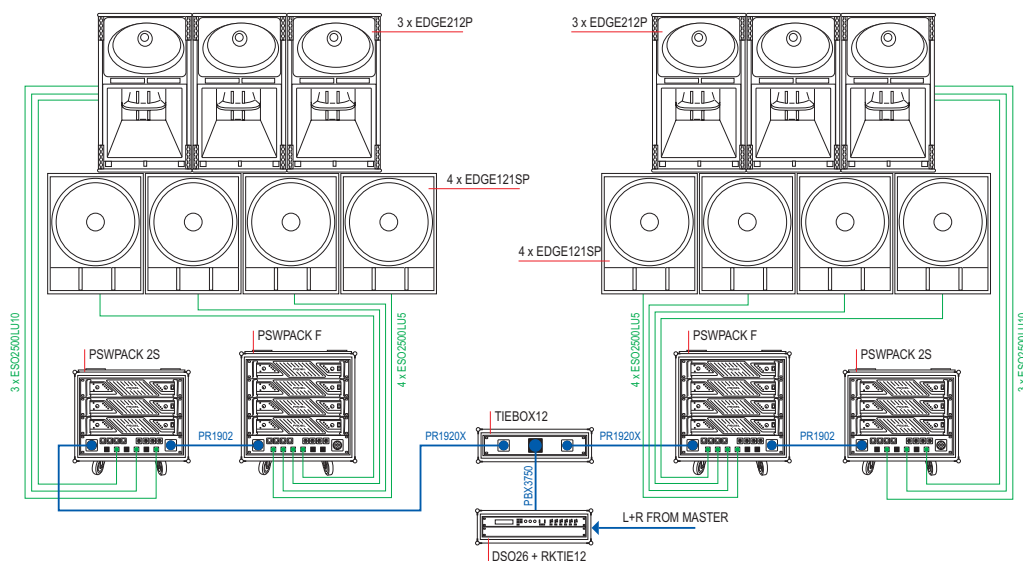

PSWPACK 2S	amplifier rack for 3 x EDGE212P
PSW2600	stereo mode (LO1+HI1)
PSW2600	stereo mode (LO2+HI2)
PSW2600	stereo mode (LO3+HI3)
CRK401	output/signal panel MIX+XLR/SPEAKON
CSP99	power panel 16A plug
CP047B02	8 U professional rack case

PSWPACK F	amplifier rack for 4 x EDGE121SP
PSW2600	bridge mode (SUB1)
PSW2600	bridge mode (SUB2)
PSW2600	bridge mode (SUB3)
PSW2600	bridge mode (SUB4)
CRK401	output/signal panel MIX+XLR/SPEAKON
CSP9932	power panel 32A plug
CP047C02	10 U professional rack case

CAD simulation

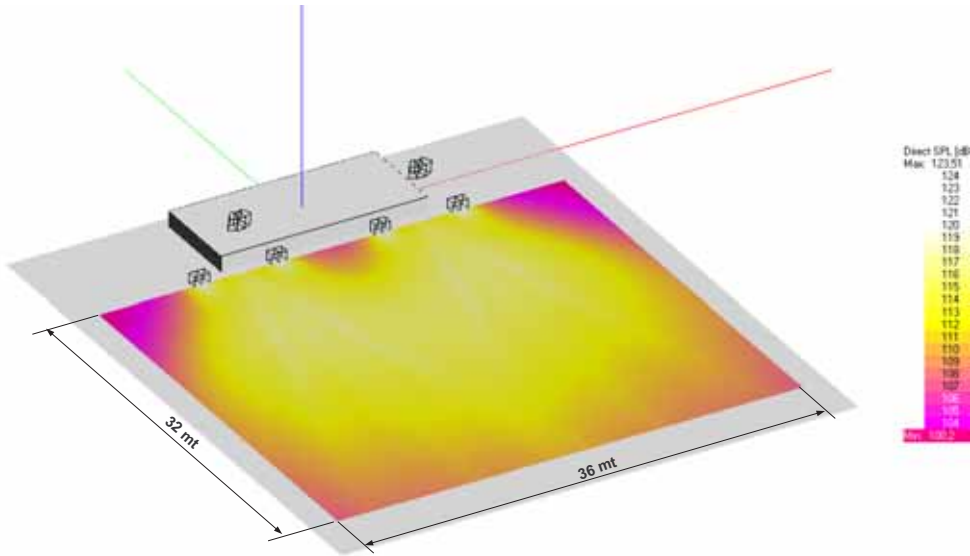

Systems	6 x EDGE212P 8 x EDGE121SP
Power Amplifiers	14 x Proel PSW2600
Signal Processing	1 x Proel DSO26
Sound Level	112 dB average on 32 x 36 mt area
Estimated Audience	4000 - 5000 people
Total amp. continuous power	21600 W

7. Typical applications

7.4 Large concert system

The following example gives an example of a notably bigger configuration for the sound reinforcement of a large live concert. The configuration of the system is 4-way. In order to increase the range of the array there are two superimposed lines of EDGE212P with the high frequency horns matched.

Block diagram

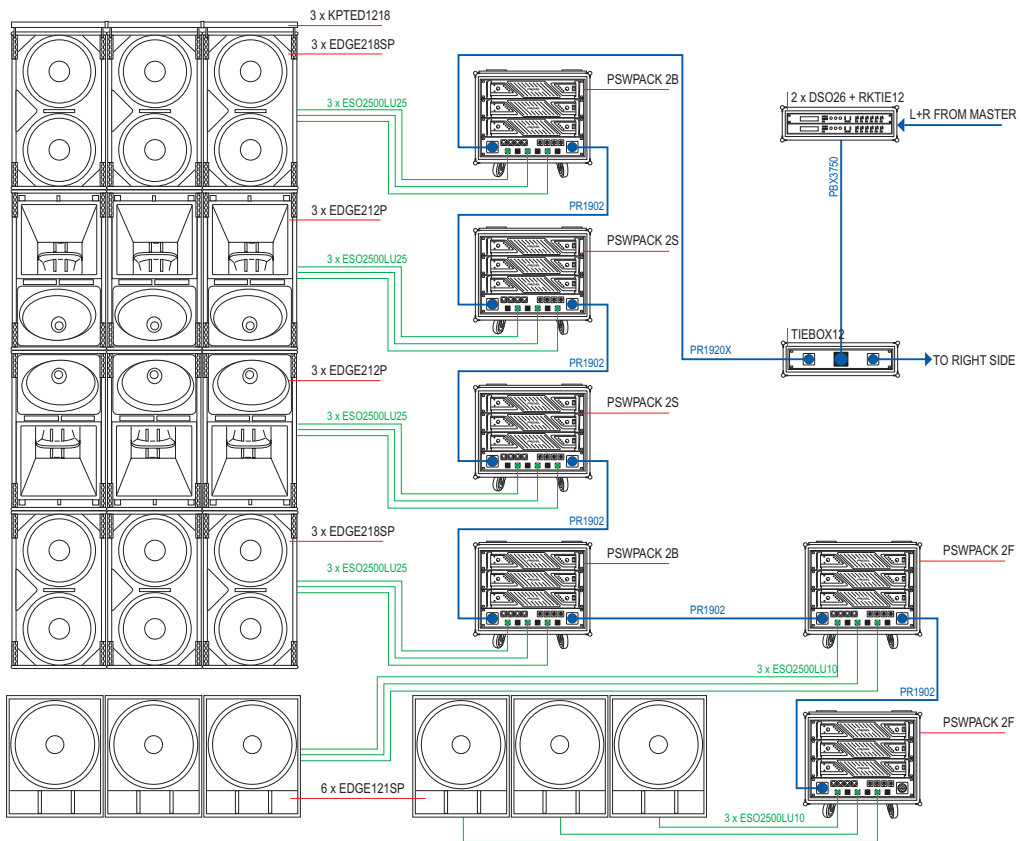

PSWPACK 2S		amplifier rack for 3 x EDGE212P
PSW2600	stereo mode (LO1+HI1)	
PSW2600	stereo mode (LO2+HI2)	
PSW2600	stereo mode (LO3+HI3)	
CRK401	output/signal panel MIX+XLR/SPEAKON	
CSP99	power panel 16A plug	
CP047B02	8 U professional rack case	

PSWPACK 2B		amplifier rack for 3 x EDGE218SP
PSW2600	parallel mode (SUB1)	
PSW2600	parallel mode (SUB2)	
PSW2600	parallel mode (SUB3)	
CRK401	output/signal panel MIX+XLR/SPEAKON	
CSP99	power panel 16A plug	
CP047B02	8 U professional rack case	

PSWPACK 2F		amplifier rack for 3 x EDGE121P
PSW2600	bridge mode (SUB1)	
PSW2600	bridge mode (SUB2)	
PSW2600	bridge mode (SUB3)	
CRK401	output/signal panel MIX+XLR/SPEAKON	
CSP99	power panel 16A plug	
CP047B02	8 U professional rack case	

CAD simulation

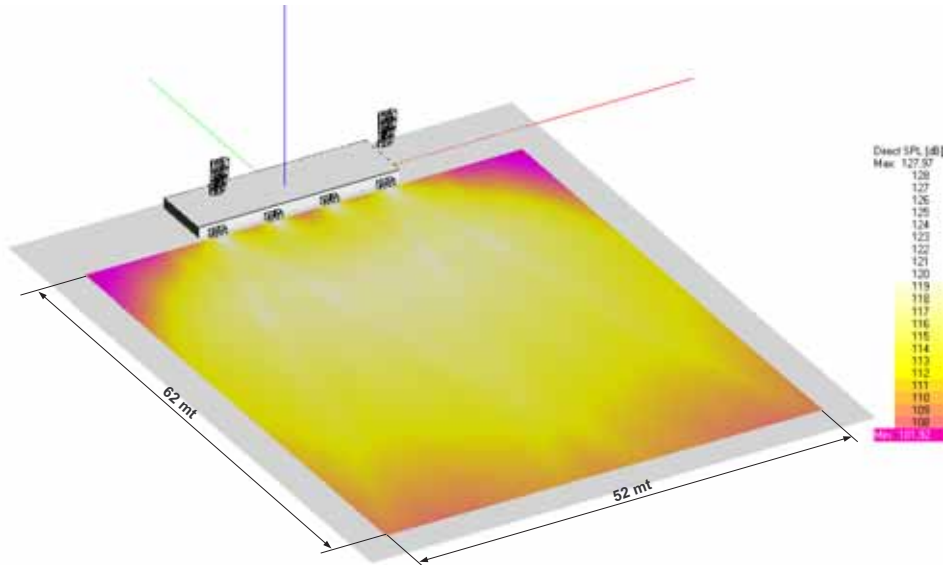

Systems	12 x EDGE212P 12 x EDGE218SP 12 x EDGE121SP
Power Amplifiers	36 x Proel PSW2600
Signal Processing	2 x Proel DSO26
Sound Level	113 dB average on 62 x 52 mt area
Estimated Audience	10000 - 15000 people
Total amp. continuous power	57600 W

PROEL

SOUND REINFORCEMENT

Proel S.p.A.

(World Headquarters - Factory)

Via alla Ruenia, 37/43

64027 Sant'Omero (TE) - ITALY

Tel. +39 0861 81241

Fax. +39 0861 887862

E-mail: info@proelgroup.com

Web: www.proelgroup.com