



Waterproof Cabinet Loudspeaker CAE-3 Series

The CAE-3 series loudspeaker offers an attractive solution to specifiers, architects and installers looking for a music quality cabinet loudspeaker for external as well as internal applications. The unit has been IP rated to IEC529 IP66 and is made from extruded aluminium with an epoxy coated aluminium grille, together with further stainless steel external hardware. A highly durable nylon/fibre multi-bracket is also included for accurate fixing to a wall etc. The unit consists of a very high quality 3.5" driver unit and 3.25" tweeter giving an efficient, dynamic response. The CAE-3 series is rated at 15 watts rms and can be ordered as 8Ω only or as a multi-impedance 100 volt, 70.7 volt & 8Ω ? unit + power tapping, via a high quality rotary power control on the rear of the unit.??

Typical installations include - Beer gardens, Patio areas in restaurants, Garden centres, Retail outlets, Gymnasiums, Changing rooms etc.



For your peace of mind and accurate system design, sample CES Audio products are extensively tested in our Anechoic Test Chamber, Withstanding/Insulation Tester and Programmable Temperature & Humidity Chamber to ensure accurate specification, safety and reliability.

All CES Audio loudspeakers are designed to withstand operating at their rated power for 100 hours in accordance with IEC 268-5 Power Handling Capacity standards.

- ▶ **Durable extruded aluminium housing.**
- ▶ **Water protected to IEC529 IP66, suitable for indoor and outdoor use.**
- ▶ **Durable Nylon/Fibre multi bracket which has a breaking load tested to 10 Kgs included.**
- ▶ **High quality 2 way system suitable for music & speech.**
- ▶ **Attractive slimline construction.**
- ▶ **Multi Impedance 15 watt 100v,70.7v & 8Ω.**
- ▶ **High quality rotary power and tappings selector control.**
- ▶ **Available in White (RAL 9003).**

Model No.	CAE-3158	CAE-3150
Rated Power (rms)	15W	
Impedance	8Ω	333Ω, 667Ω, 1300Ω, 2600Ω OFF & 8Ω
Power Taps @ 100V Power Taps @ 70.7V	n.a.	15W, 7.5W, 3.75W, OFF & 8Ω 15W, 7.5W, 3.75W, 1.9W, OFF & 8Ω
SPL (1W/1m)	88dB	
Max. SPL (15W/1m)	100dB	
Frequency Range (-10dB)	130 Hz ~ 20K Hz	
Dispersion 1K Hz/4K Hz	190° / 100°	
Ambient Temperature	-20°C ~ 60°C	
Water Protection	IEC529 IP66	
Power Selection Way	n.a.	Selecting Switch
Material	Housing: Extruded aluminium, Grille: Aluminium	
Colour/Finish	White (RAL 9003)	
Dimensions	210 (8.27) L X 114 (4.49) W X 96 (3.78) D mm. (in.)	
Net Weight (ea)	1.8 Kgs (3.97 lbs.)	2.1 Kgs (4.63 lbs.)
Shipping Weight (8 pcs)	18 Kgs (40 lbs.)	22 Kgs (49 lbs.)
Shipping Meas't (8 pcs)	3.6 cuft	
Mounting	Multi Bracket (B8-19-0091)	

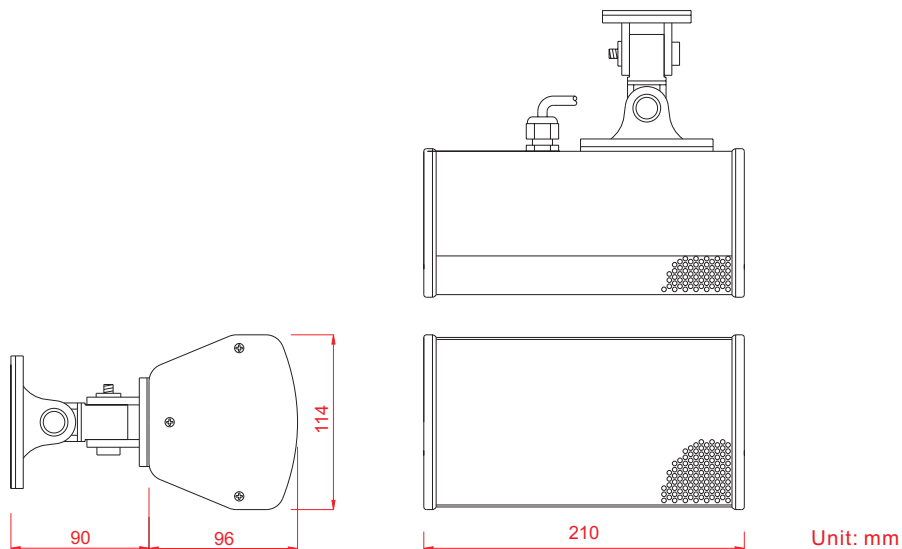

Frequency Response

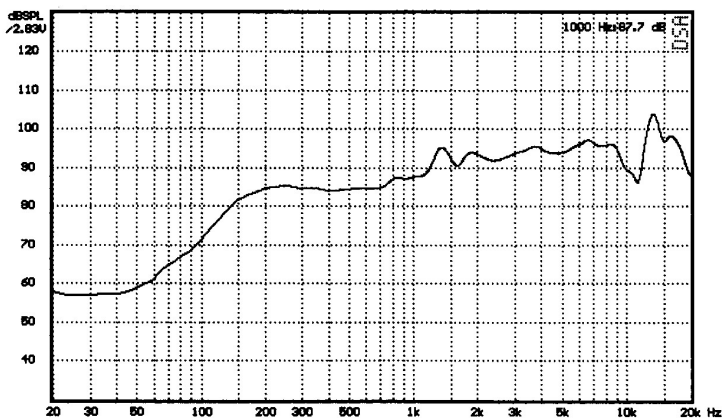

Polar Plot

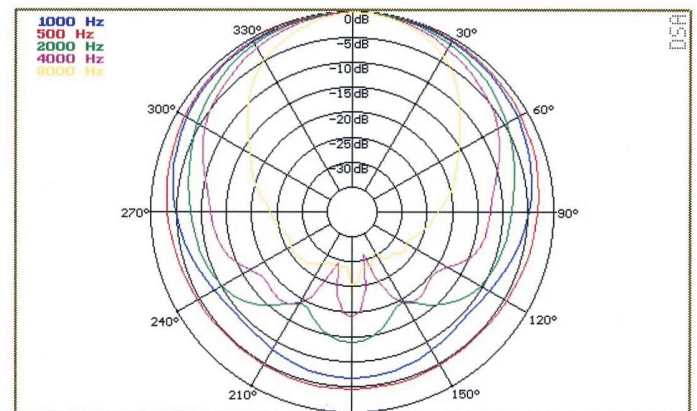

CAE-3 SERIES

Public Address Loudspeakers